

K Series

Pumps and Motors



QCC can accept no responsibility for possible errors in catalogues, brochures and other printed material. QCC reserves the right to alter its products without notice. This also applies to products already on order provided that such alterations can be made without consequential changes being necessary in specifications already agreed. All trademarks in this material are property of the respective companies. QCC and the QCC logotype are trademarks of QCC, LLC. All rights reserved.

From hydraulic motors, pumps, actuators and hydrostatic steering components, to proportional hydraulics and electronics. QCC components redefine the leading edge.



Designers and manufacturers of monoblock valves and stack valves with an array of spool types and actions, port locations, and open/closed center options, we custom-design valves for specific configurations.



A pioneer in hydraulic product miniaturization and in the development of pilot-operated relief valves, cartridge valves and HIC's, QCC has solutions for all your fluid power applications.



Our hydraulic gear pumps, motors and cost-effective multi-circuit components, AC and DC power unit lines, flow dividers and rotary shear valves serve for a multitude of applications.



Index

| | |
|------------------|----|
| Quick Reference | 4 |
| K Series Pumps | 6 |
| MK Series Motors | 19 |
| Order Code | 28 |

K Series Hydraulic Pumps and Motors

Features

K Series hydraulic pumps and motors provide the ultimate in flexibility, with numerous displacements, features, and shaft/port options. The K Series has an excellent reputation for rugged, dependable performance at continuous pressures to 3000 psi (207 bar) and speeds to 3000 rpm.

K pumps are available in nine displacements from .86 to 3.88 in³/rev (14,1 to 63,6 cm³/rev); MK motors in seven displacements from 1.29 to 3.88 in³/rev (21,1 to 63,6 cm³/rev). Complete information can be found by referring to the specific sections of this catalog.

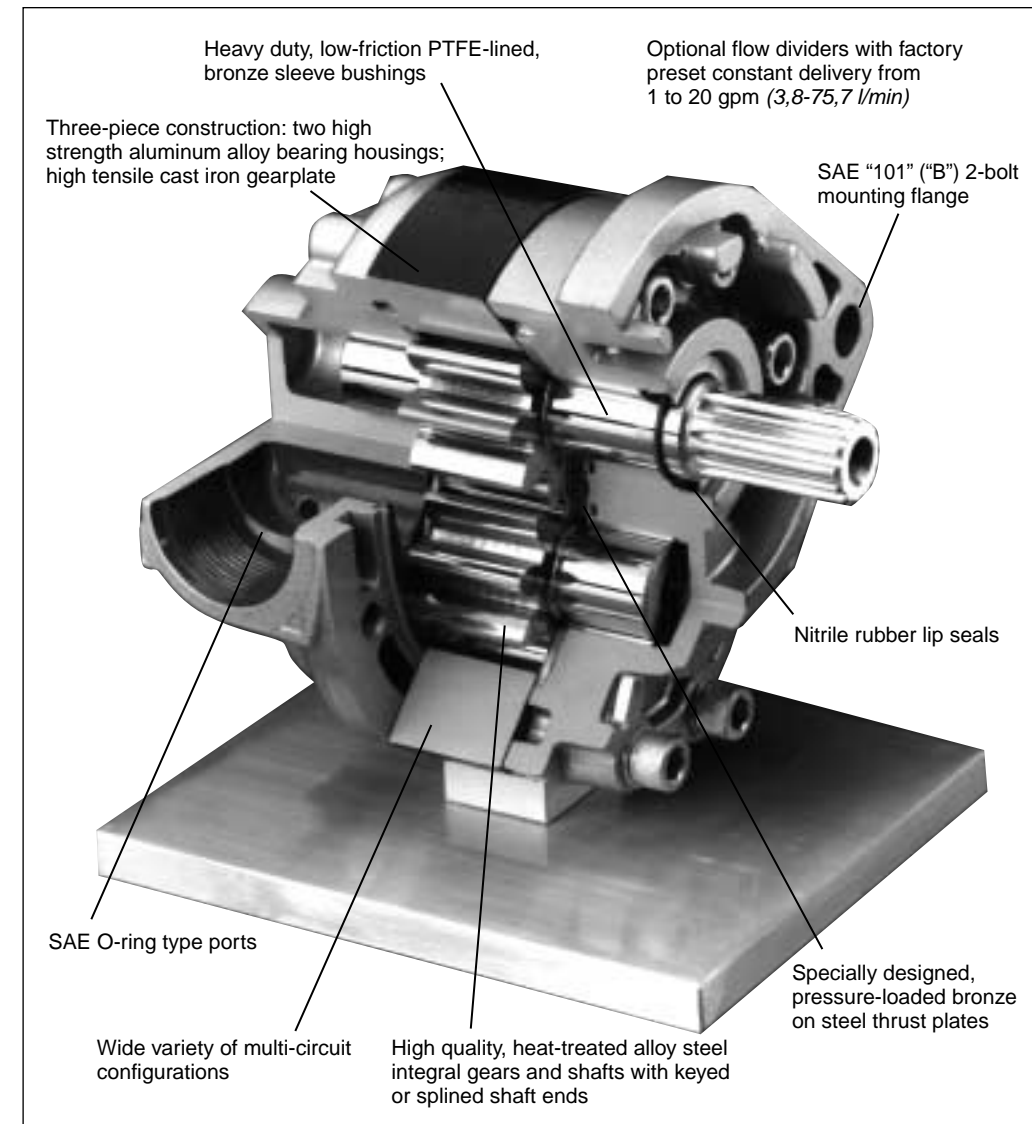

ISO 9001 quality management

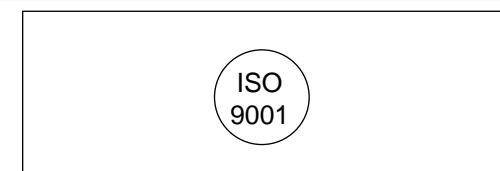

The quality management of QCC Hydraulics product development, design, production and sale has been approved in accordance with the international standard ISO 9001. The approval was effected by BSI, the British Standards Institution, who is currently checking that QCC Hydraulics fulfils the ISO standard specifications. In North America, the approval was effected by UL, Underwriters Laboratories, Inc.

K Series Hydraulic Pumps and Motors

| Pump or Motor Displacement Code | 086K | 108K | 129K | 151K | 194K | 237K | 280K | 323K | 388K |
|--|-------------|--------------|--------------|--------------|--------------|--------------|--------------|--------------|--------------|
| Theoretical displacement in ³ /rev (cm ³ /rev) | .86 (14,09) | 1.08 (17,70) | 1.29 (21,14) | 1.51 (24,74) | 1.94 (31,79) | 2.37 (38,84) | 2.80 (45,88) | 3.23 (52,93) | 3.88 (63,58) |
| Pumps max. continuous pressure psi (bar) | 3000 (207) | 3000 (207) | 3000 (207) | 3000 (207) | 3000 (207) | 3000 (207) | 3000 (207) | 3000 (207) | 2500 (172) |
| Motors max. continuous pressure psi (bar) | 2500 (172) | 2500 (172) | 2500 (172) | 2500 (172) | 2500 (172) | 2500 (172) | 2500 (172) | 2500 (172) | 2500 (172) |
| Pump-maximum speed (rpm) | 3000 | 3000 | 3000 | 3000 | 3000 | 3000 | 3000 | 3000 | 2750 |
| Motor-maximum speed (rpm) | - | - | 3000 | 3000 | 3000 | 3000 | 3000 | 3000 | 2750 |

| Model Number | 086K | 108K | 129K | 151K | 194K | 237K | 280K | 323K | 388K |
|-----------------|---------------|---------------|---------------|---------------|---------------|---------------|---------------|---------------|---------------|
| "A" inches (mm) | 4.15 (105,41) | 4.25 (107,95) | 4.35 (110,49) | 4.45 (113,03) | 4.65 (118,11) | 4.85 (123,19) | 5.05 (128,27) | 5.25 (133,35) | 5.55 (140,97) |
| "B" inches (mm) | 3.14 (79,76) | 3.24 (82,30) | 3.34 (84,84) | 3.44 (87,38) | 3.64 (92,46) | 3.84 (97,54) | 4.04 (102,62) | 4.24 (107,70) | 4.54 (115,32) |

Dimensions

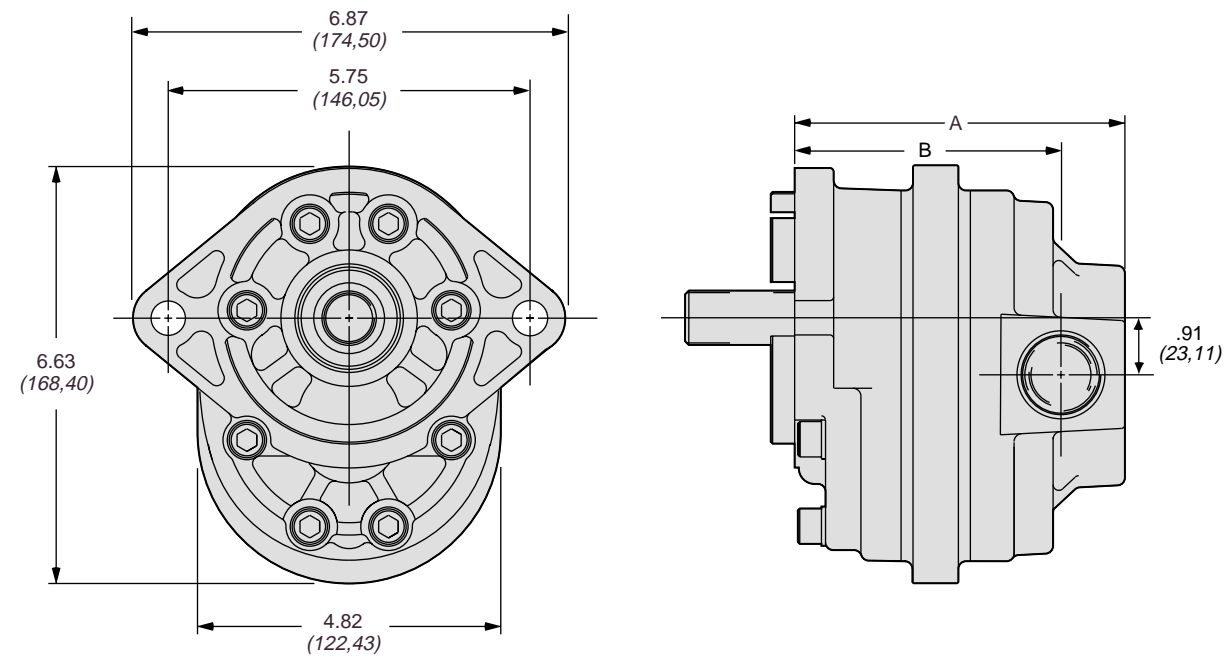

Dimensions shown: inches (mm)

All metric values are secondary and for reference only.

K Series Hydraulic Pumps and Motors

| K Pumps | | gpm (l/min) | | | | | | | | |
|--------------------------|------------|------------------------|-------------|-------------|--------------|--------------|---------------|----------------|--------------|---------------|
| rpm | psi (bar) | 086K | 108K | 129K | 151K | 194K | 237K | 280K | 323K | 388K |
| 1800 | 500 (34) | 6.4 (24,2) | 8.2 (31,0) | 9.9 (37,5) | 11.5 (43,5) | 14.9 (56,4) | 18.2 (68,9) | 21.5 (81,4) | 24.9 (94,2) | 30.0 (113,5) |
| | 1000 (69) | 6.3 (23,8) | 8.1 (30,7) | 9.8 (37,1) | 11.4 (43,1) | 14.6 (55,3) | 18.0 (68,1) | 21.4 (81,0) | 24.7 (93,5) | 29.8 (112,8) |
| | 2000 (138) | 6.1 (23,1) | 7.9 (29,9) | 9.7 (36,7) | 11.1 (42,0) | 14.3 (54,1) | 17.7 (67,0) | 21.0 (79,5) | 24.3 (92,0) | 29.2 (110,5) |
| | 2500 (172) | 6.0 (22,7) | 7.8 (29,5) | 9.7 (36,7) | 11.1 (42,0) | 14.1 (53,4) | 17.6 (66,6) | 21.0 (79,5) | 24.2 (91,6) | 29.0 (109,8) |
| | 3000 (207) | 5.9 (22,3) | 7.7 (29,1) | 9.7 (36,7) | 11.0 (41,6) | 13.9 (52,6) | 17.5 (66,2) | 20.8 (78,7) | 24.0 (90,8) | - |
| 3000 | 500 (34) | 10.9 (41,3) | 13.9 (52,6) | 16.7 (63,2) | 19.5 (73,8) | 25.0 (94,6) | 30.6 (115,8) | 36.0 (136,3) | 41.3 (156,3) | 44.7* (169,2) |
| | 1000 (69) | 10.8 (40,9) | 13.7 (51,9) | 16.7 (63,2) | 19.4 (73,4) | 24.8 (93,9) | 30.3 (114,7) | 35.7 (135,1) | 41.0 (155,2) | 44.9* (169,9) |
| | 2000 (138) | 10.5 (39,7) | 13.5 (51,1) | 16.5 (62,4) | 19.1 (72,3) | 24.3 (92,0) | 29.9 (113,2) | 35.3 (133,6) | 40.5 (153,3) | 44.5* (168,4) |
| | 2500 (172) | 10.4 (39,4) | 13.4 (50,7) | 16.4 (62,1) | 18.9 (71,5) | 24.2 (91,6) | 29.8 (112,8) | 35.1 (132,8) | 40.3 (152,5) | 44.3* (167,7) |
| | 3000 (207) | 10.3 (38,9) | 13.2 (49,9) | 16.4 (62,1) | 18.8 (71,2) | 23.9 (90,5) | 29.6 (112,0) | 34.9 (132,1) | 40.0 (151,4) | - |
| Input Horsepower hp (kW) | | | | | | | | | | |
| rpm | psi (bar) | 086K | 108K | 129K | 151K | 194K | 237K | 280K | 323K | 388K |
| 1800 | 500 (34) | 2.6 (1,9) | 3.1 (2,3) | 3.6 (2,7) | 4.2 (3,1) | 5.3 (4,0) | 6.5 (4,8) | 7.6 (5,7) | 8.8 (6,6) | 11.9 (8,9) |
| | 1000 (69) | 5.2 (3,9) | 6.3 (4,7) | 7.3 (5,4) | 8.3 (6,2) | 10.2 (7,6) | 12.2 (9,1) | 14.6 (10,9) | 17.4 (13,0) | 21.5 (16,0) |
| | 2000 (138) | 10.8 (8,1) | 13.1 (9,8) | 15.2 (11,3) | 17.0 (12,7) | 20.6 (15,4) | 24.2 (18,0) | 28.7 (21,4) | 34.7 (25,9) | 40.6 (30,3) |
| | 2500 (172) | 13.9 (10,4) | 16.8 (12,5) | 19.4 (14,5) | 21.7 (16,2) | 26.1 (19,5) | 30.5 (22,7) | 36.0 (26,8) | 43.5 (32,4) | 50.3 (37,5) |
| | 3000 (207) | 16.9 (12,6) | 20.6 (15,4) | 23.9 (17,8) | 26.2 (19,5) | 30.9 (23,0) | 35.8 (26,7) | 42.3 (31,5) | 51.9 (38,1) | - |
| 3000 | 500 (34) | 4.5 (3,4) | 5.6 (4,2) | 6.6 (4,9) | 7.5 (5,6) | 9.6 (7,2) | 11.7 (8,7) | 14.3 (10,7) | 17.3 (12,9) | 21.1* (15,7) |
| | 1000 (69) | 8.9 (6,6) | 11.2 (8,4) | 13.0 (9,7) | 14.9 (11,1) | 18.2 (13,6) | 22.0 (16,4) | 26.8 (20,0) | 33.1 (24,7) | 35.8* (26,7) |
| | 2000 (138) | 18.3 (13,6) | 22.7 (16,9) | 26.5 (19,8) | 29.7 (22,1) | 36.2 (27,0) | 42.4 (31,6) | 50.2 (37,4) | 60.1 (44,8) | 63.0* (47,0) |
| | 2500 (172) | 23.6 (17,6) | 28.5 (21,3) | 32.8 (24,5) | 37.0 (27,6) | 44.5 (33,2) | 52.3 (39,0) | 60.7 (45,3) | 71.4 (53,2) | 77.5* (57,8) |
| | 3000 (207) | 28.5 (21,3) | 34.2 (25,5) | 39.7 (29,6) | 44.3 (33,0) | 53.3 (39,5) | 60.8 (45,3) | 70.0 (52,2) | 82.1 (61,2) | - |
| MK Motors | | Input Flow gpm (l/min) | | | | | | | | |
| rpm | psi (bar) | M129K | M151K | M194K | M237K | M280K | M323K | M388K | | |
| 1800 | 500 (34) | 10.2 (38,6) | 11.9 (45,0) | 15.3 (57,9) | 18.6 (70,4) | 21.9 (82,9) | 25.3 (95,8) | 30.3 (114,7) | | |
| | 1000 (69) | 10.5 (39,7) | 12.2 (46,2) | 15.5 (58,7) | 18.9 (71,5) | 22.2 (84,0) | 25.5 (96,5) | 30.6 (115,8) | | |
| | 2000 (138) | 10.9 (41,3) | 12.6 (47,7) | 16.0 (60,6) | 19.3 (73,0) | 22.6 (85,5) | 25.9 (98,0) | 31.2 (118,1) | | |
| | 2500 (172) | 11.1 (42,0) | 12.8 (48,4) | 16.2 (61,3) | 19.5 (73,8) | 22.8 (86,3) | 26.1 (98,8) | 34.2 (129,4) | | |
| 3000 | 500 (34) | 17.0 (64,3) | 19.8 (74,9) | 25.4 (96,1) | 30.9 (117,0) | 36.5 (138,1) | 42.0 (159,0) | 46.2* (174,9) | | |
| | 1000 (69) | 17.2 (65,1) | 20.1 (76,1) | 25.6 (96,9) | 31.2 (118,1) | 36.7 (138,9) | 42.2 (159,7) | 46.5* (176,0) | | |
| | 2000 (138) | 17.6 (66,6) | 20.5 (77,6) | 26.1 (98,8) | 31.6 (119,6) | 37.1 (140,4) | 42.5 (160,9) | 47.1* (178,3) | | |
| | 2500 (172) | 17.8 (67,4) | 20.7 (78,3) | 26.3 (99,5) | 31.8 (120,4) | 37.2 (140,8) | 42.6 (161,2) | 51.7* (195,7) | | |
| Torque lb-in (daNm) | | | | | | | | | | |
| rpm | psi (bar) | M129K | M151K | M194K | M237K | M280K | M323K | M388K | | |
| 1800 | 500 (34) | 51.6 (0,6) | 63.2 (0,7) | 86.9 (1,0) | 111.4 (1,3) | 135.5 (1,5) | 158.5 (1,8) | 198.4 (2,2) | | |
| | 1000 (69) | 110.4 (1,2) | 142.6 (1,6) | 205.0 (2,3) | 266.7 (3,0) | 327.2 (3,7) | 386.5 (4,4) | 468.1 (5,3) | | |
| | 2000 (138) | 228.9 (2,6) | 297.8 (3,4) | 430.4 (4,9) | 560.7 (6,3) | 688.8 (7,8) | 815.1 (9,2) | 994.8 (11,2) | | |
| | 2500 (172) | 288.5 (3,3) | 373.6 (4,2) | 537.8 (6,1) | 699.4 (7,9) | 858.6 (9,7) | 1015.6 (11,5) | 1300.0 (14,7) | | |
| 3000 | 500 (34) | 51.5 (0,6) | 62.6 (0,7) | 93.4 (1,1) | 126.2 (1,4) | 148.6 (1,7) | 148.2 (1,7) | 145.0* (1,6) | | |
| | 1000 (69) | 104.8 (1,2) | 133.5 (1,5) | 191.0 (2,2) | 246.9 (2,8) | 297.9 (3,4) | 340.3 (3,8) | 406.2* (4,6) | | |
| | 2000 (138) | 228.6 (2,6) | 291.3 (3,3) | 411.5 (4,6) | 528.5 (6,0) | 642.5 (7,3) | 753.4 (8,5) | 944.5* (10,7) | | |
| | 2500 (172) | 299.2 (3,4) | 378.1 (4,3) | 534.4 (6,0) | 689.4 (7,8) | 837.7 (9,5) | 974.4 (11,0) | 1275.0* (14,4) | | |

Test data at 175 SUS Hydraulic Oil @ 120° F (49° C).
For higher speeds consult factory.

* Performance data rated at 2750 rpm.
All metric values are secondary and for reference only.

K Series Hydraulic Pumps

Specifications

| Model | Displacement in ³ /rev (cm ³ /rev) | Gear Width in. (mm) |
|-------|--|---------------------|
| 086K | .86 (14,09) | 0.40 (10,16) |
| 108K | 1.08 (17,70) | 0.50 (12,70) |
| 129K | 1.29 (21,14) | 0.60 (15,24) |
| 151K | 1.51 (24,74) | 0.70 (17,78) |
| 194K | 1.94 (31,79) | 0.90 (22,86) |
| 237K | 2.37 (38,84) | 1.10 (27,94) |
| 280K | 2.80 (45,88) | 1.30 (33,02) |
| 323K | 3.23 (52,93) | 1.50 (38,10) |
| 388K | 3.88 (63,58) | 1.80 (45,72) |

Note: Theoretical pump delivery in gpm (*l/min*) is determined by multiplying displacement-in³/rev (cm³/rev) –by desired pump rpm and dividing by 231 (1000).

K pumps have a pressure-balanced design for high volumetric and mechanical efficiencies. They feature three-piece construction with two lightweight, high strength aluminum alloy bearing housings combined with a high tensile cast iron center gear plate. Integral gears and shafts are made of heat-treated alloy steel. Standard features include straight, keyed shafts or splined shafts; heavy-duty sleeve bearings; nitrile rubber lip seals; and side SAE O-ring type ports. Optional flow dividers are available with factory preset constant delivery from 1 to 20 gpm (3,8 to 75,7 *l/min*) at the regulated (priority) flow port.

| | |
|-------------------------------------|--|
| Operating Pressures | 3000 psi (207 bar) continuous - 388K-2500 psi (172 bar) cont. |
| Recommended Operating Speeds | To 3000 rpm. 388K to 2750 rpm. |
| Mounting | SAE 2-bolt code "101" ("B"). |
| Shafts | 1.00" (25,40 mm) diameter straight keyed shaft, standard. .86" (21,84 mm) - 13-tooth splined shafts, standard. 1.00" (25,40 mm) - 15-tooth splined shaft, optional. Other shafts available upon request. |
| Shaft Rotation | Clockwise. Counterclockwise. (When viewed from shaft end) |
| Seals | Nitrile rubber standard. High pressure or fluoroelastomer seals, optional. |
| Bearings | Heavy-duty, low-friction PTFE-lined bronze sleeve bushings. |
| Porting | SAE O-ring side location, standard. End or combination location, optional. |
| Optional Flow Dividers | Pre-set at factory to deliver a constant flow. 1 to 20 gpm (3,8 to 75,7 <i>l/min</i>) at the regulated flow port. Flow divider incorporates relief valve in the priority section only. Pressures to 2250 psi (155 bar) continuous. |
| Weight | 13 to 22 pounds (5,9 to 10,0 kg). |

All metric values are secondary and for reference only.

K Series Hydraulic Pumps

Dimensions

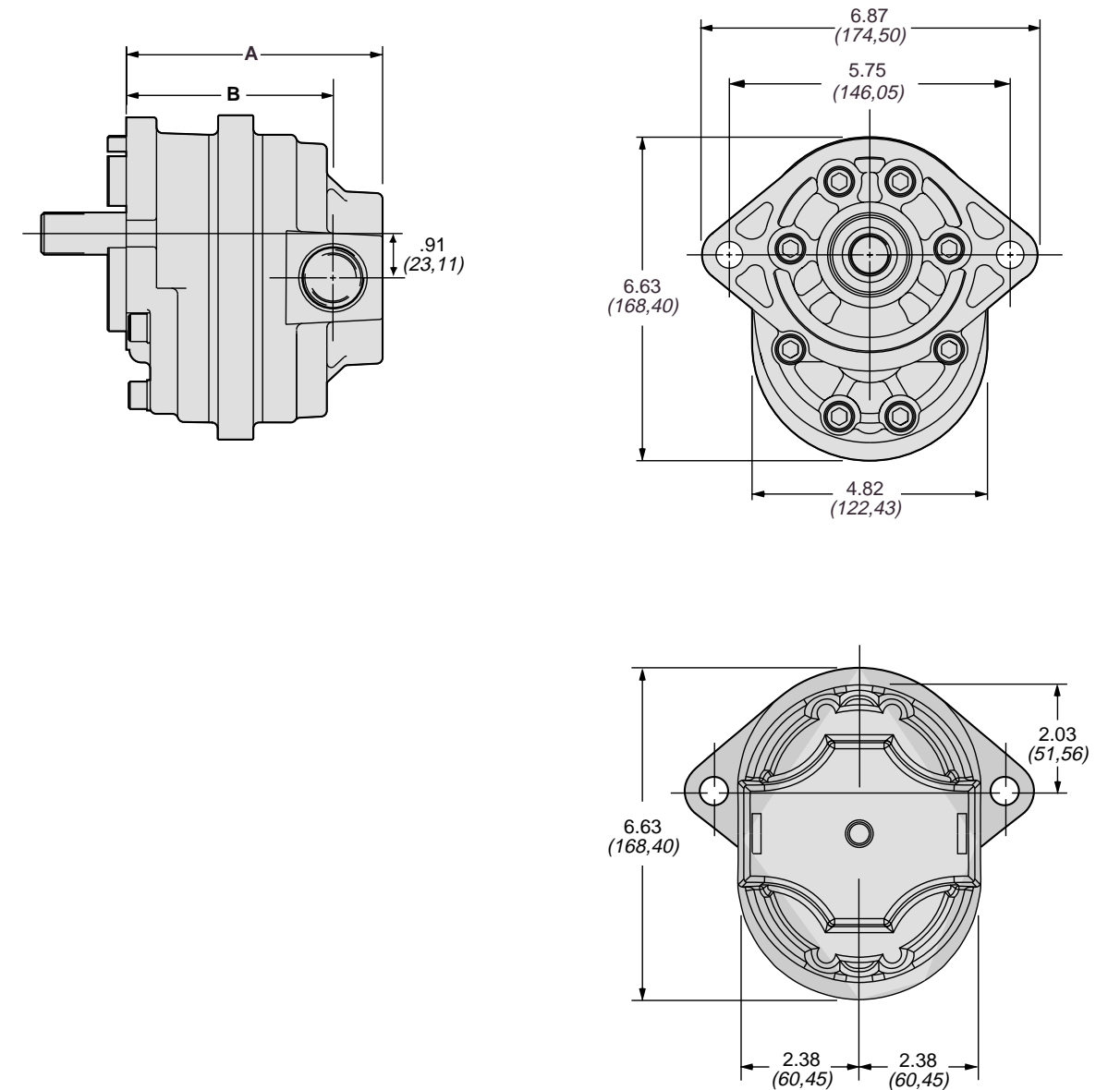

| Type | Dimension "A" | Dimension "B" | Type | Dimension "A" | Dimension "B" |
|------|---------------|---------------|------|---------------|---------------|
| 086K | 4.16 (105,66) | 3.14 (79,76) | 237K | 4.86 (123,44) | 3.84 (97,54) |
| 108K | 4.26 (108,20) | 3.24 (82,30) | 280K | 5.06 (128,52) | 4.04 (102,62) |
| 129K | 4.36 (110,74) | 3.34 (84,84) | 323K | 5.26 (133,60) | 4.24 (107,70) |
| 151K | 4.46 (113,28) | 3.44 (87,38) | 388K | 5.56 (141,22) | 4.54 (115,32) |
| 194K | 4.66 (118,36) | 3.64 (92,46) | | | |

Dimensions shown: inches (mm)

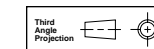

All metric values are secondary and for reference only.

K Series Multi-Circuit Pumps

Multi-Circuit Pumps

K Series hydraulic pumps can readily be adapted for use in multi-circuit pump arrangements. Multi-circuit pumps combine the capability of several pumps into one, utilizing a single drive point. This reduces the number of components as well as hoses, fittings and installation time. Operating costs are lower because less horsepower and fuel are required.

K pumps can be combined to create dual, triple, or quad pumps. Multi-circuit K pumps can have either a) separate inlets and outlets or b) one common inlet and separate outlets. Consult factory for applications with common inlets for proper pump configuration.

Dimensions

Pump with Flow Divider

(Shaft Extension "AS"
CCW Shaft Rotation Shown)

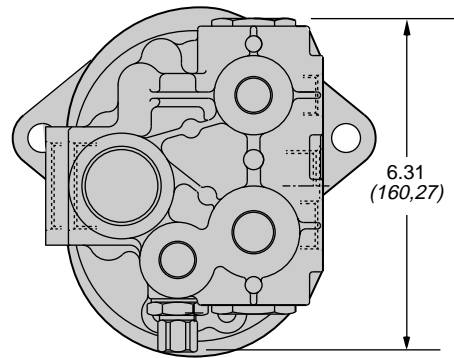
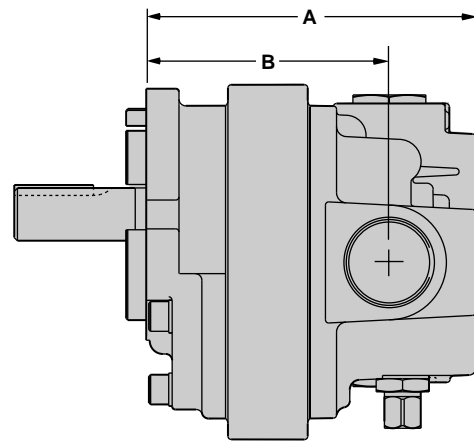

| Type | Dimension "A" | Dimension "B" | Type | Dimension "A" | Dimension "B" |
|------|---------------|---------------|------|---------------|---------------|
| 086K | 5.02 (127,51) | 3.40 (86,36) | 237K | 5.72 (145,29) | 4.10 (104,14) |
| 108K | 5.12 (130,05) | 3.50 (88,90) | 280K | 5.92 (150,37) | 4.30 (109,22) |
| 129K | 5.22 (132,59) | 3.60 (91,44) | 323K | 6.12 (155,45) | 4.50 (114,30) |
| 151K | 5.32 (135,13) | 3.70 (93,98) | 388K | 6.42 (163,07) | 4.80 (121,92) |
| 194K | 5.52 (140,21) | 3.90 (99,06) | | | |

Dimensions shown: inches (mm)

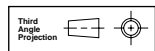

All metric values are secondary and for reference only.

K Series Multi-Circuit Pumps

Sizing Multi-Circuit Pumps

When sizing multi-circuit pumps, maximum pressure units (MPU) cannot exceed a total of 16,600 units. Total MPUs are calculated by adding together the in³/rev displacement times the maximum pressure - psi of each pump section. The second, third, and fourth sections should not exceed a sum of 7000 MPUs. Generally, the pump section with the largest individual MPUs should be the first section.

Example: 237/194/194K triple

If the front section needs to run at 2500 psi, how would you calculate the pressures for sections two and three?

- 1st Section:
2.37 in³/rev x 2500 psi = 5925 MPUs
- Sections 2 & 3 would divide 7000 MPUs.
If they were divided equally, each section could run at 1800 psi: 1.94 in³/rev x 1800 psi = 3492 x 2 pumps = 6984 MPUs. Any combination is possible as long as the total does not exceed 7000 MPUs.
- 3) The total of all 3 sections easily conforms to the 16600 total limit: 5925 + 6984 = 12909 MPUs.

Dimensions

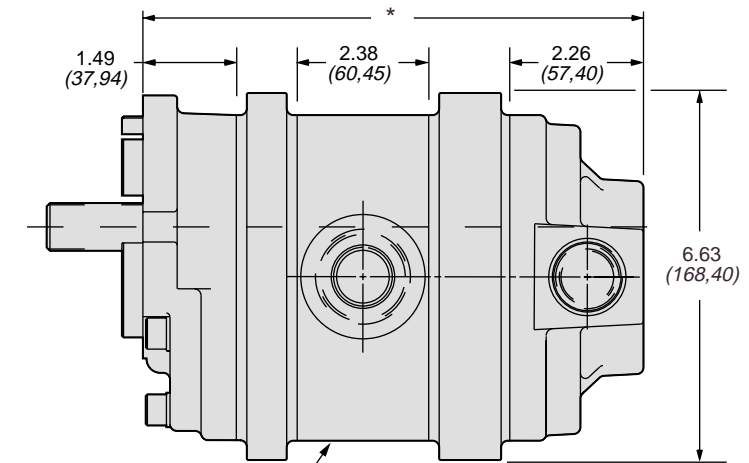
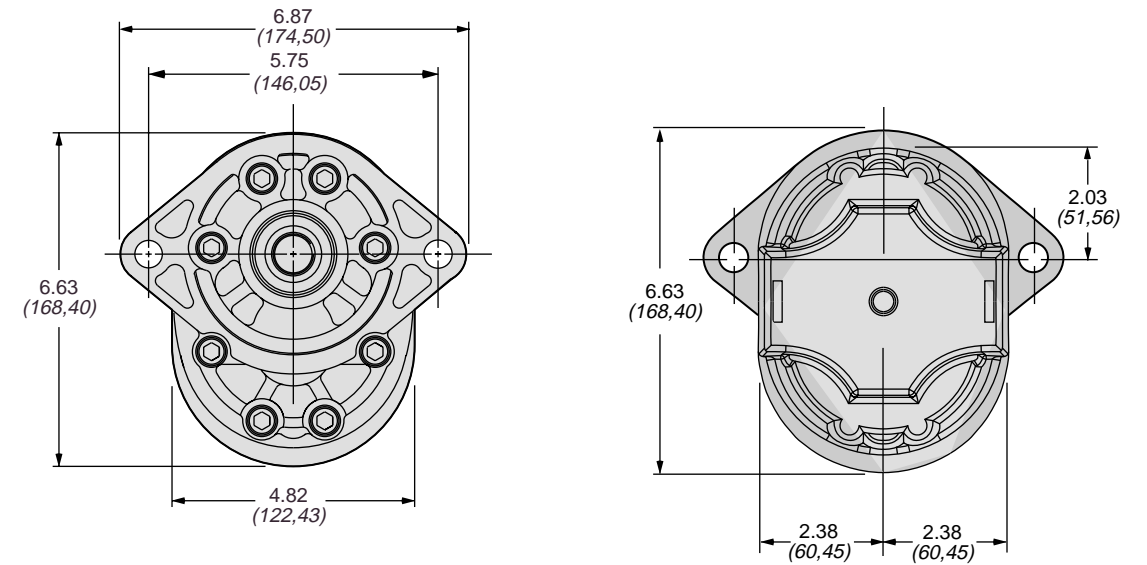

BEARING PLATE

NOTE: One Bearing Plate is required for each additional Pump Section.

| Section Displacement | Gear plate width per section "X", "Y" or "Z" | Section Displacement | Gear plate width per section "X", "Y" or "Z" |
|----------------------|--|----------------------|--|
| 086K | .40 (10,16) | 237K | 1.10 (27,94) |
| 108K | .50 (12,70) | 280K | 1.30 (33,02) |
| 129K | .60 (15,24) | 323K | 1.50 (38,10) |
| 151K | .70 (17,78) | 388K | 1.80 (45,72) |
| 194K | .90 (22,86) | | |

Dimensions shown: inches (mm)

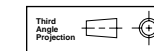

All metric values are secondary and for reference only.

K Series Hydraulic Pumps

Flow Dividers

Priority flow dividers can be added to K pumps, splitting the flow from the last pumping section into priority and secondary flows. The priority flow, preset at the factory, can deliver from 1.0 to 20.0 gpm (3,8 to 75,7 l/min). Priority flow is pressure compensated, extremely stable, and has rapid response time. Oil not used by the primary circuit can be returned to tank or used by an

additional circuit via the secondary port. Priority and secondary circuits do not interact. Maximum total flow capacity is 38 gpm (143,8 l/min).

Model 086K Typical Performance Data

| Pressure | Flow Input | | | | | | | | | |
|--------------------|------------|-------------|-----------|-------------|-----------|------|------|------|------|------|
| | gpm hp | l/min kw | gpm hp | l/min kw | gpm hp | | | | | |
| 500 psi (34 bar) | 1.6 | 6,1 | 4.2 | 15,9 | 6.4 | 24,2 | 8.6 | 32,5 | 10.9 | 41,3 |
| | 0.7 | 0,5 | 1.7 | 1,3 | 2.6 | 1,9 | 3.5 | 2,6 | 4.5 | 3,4 |
| 1000 psi (69 bar) | 1.5 | 5,7 | 4.1 | 15,5 | 6.3 | 23,8 | 8.5 | 32,2 | 10.8 | 40,9 |
| | 1.5 | 1,1 | 3.4 | 2,5 | 5.2 | 3,9 | 7.0 | 5,2 | 8.9 | 6,6 |
| 1500 psi (103 bar) | 1.4 | 5,3 | 4.0 | 15,1 | 6.2 | 23,5 | 8.4 | 31,8 | 10.6 | 40,1 |
| | 2.2 | 1,6 | 5.2 | 3,9 | 7.9 | 5,9 | 10.6 | 7,9 | 13.7 | 10,2 |
| 2000 psi (138 bar) | 1.2 | 4,5 | 3.9 | 14,8 | 6.1 | 23,1 | 8.3 | 31,4 | 10.5 | 39,7 |
| | 3.0 | 2,2 | 7.2 | 5,4 | 10.8 | 8,1 | 14.4 | 10,7 | 18.3 | 13,6 |
| 2500 psi (172 bar) | 1.1 | 4,2 | 3.8 | 14,4 | 6.0 | 22,7 | 8.3 | 31,4 | 10.4 | 39,4 |
| | 3.9 | 2,9 | 9.2 | 6,9 | 13.9 | 10,4 | 18.2 | 13,6 | 23.6 | 17,6 |
| 3000 psi (207 bar) | 1.0 | 3,8 | 3.7 | 14,0 | 5.9 | 22,3 | 8.2 | 31,0 | 10.3 | 39,0 |
| | 4.6 | 3,4 | 11.0 | 8,2 | 16.5 | 12,3 | 21.8 | 16,3 | 28.1 | 21,0 |
| rpm | 500 | 1200 | 1800 | 2400 | 3000 | | | | | |

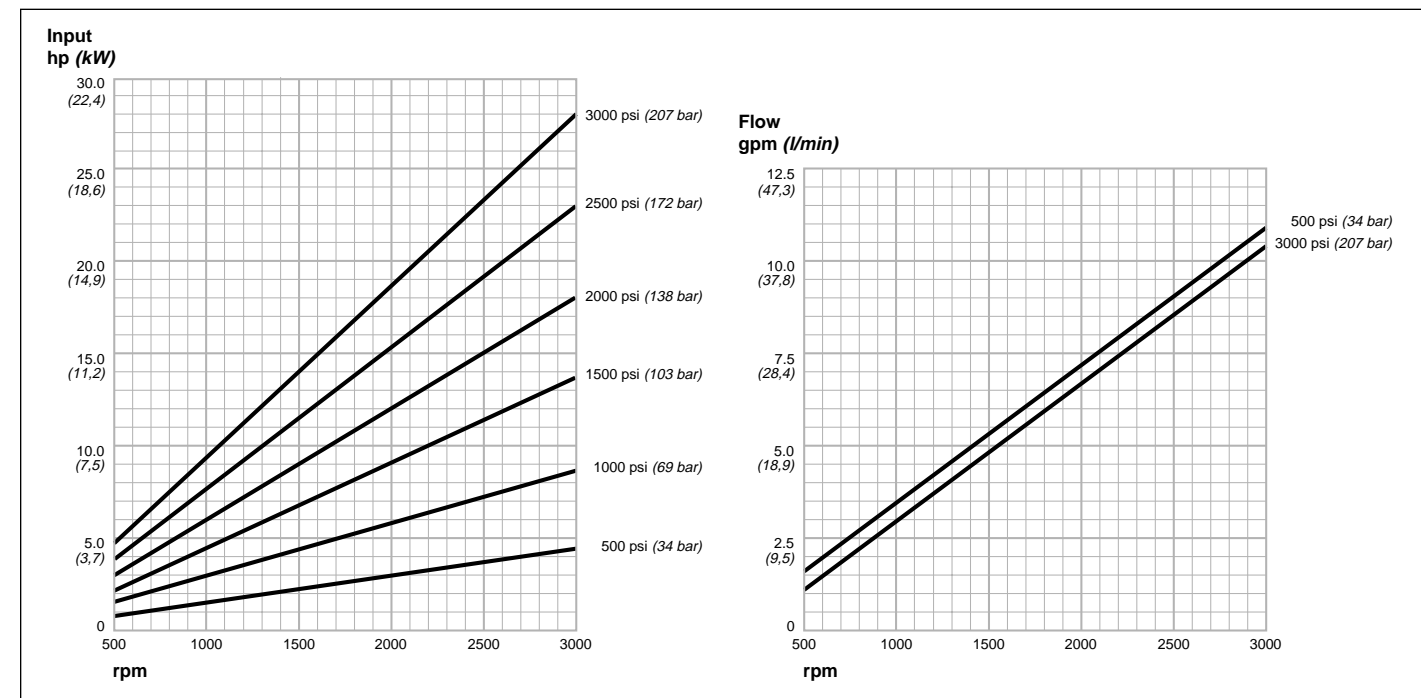

All metric values are secondary and for reference only.

K Series Hydraulic Pumps

Flow Dividers (continued)

Flow divider pressure capacity is 2250 psi (155 bar). The priority circuit has an integral, adjustable, direct acting relief valve with internal drain. Relief valve is adjustable from 500 to 2250 psi (34 to 155 bar). External relief valve drain is optional.

Model 108K Typical Performance Data

| Pressure | Flow Input | | | | | | | | | |
|--------------------|------------|-------------|-----------|-------------|-----------|------|------|------|------|------|
| | gpm hp | l/min kw | gpm hp | l/min kw | gpm hp | | | | | |
| 500 psi (34 bar) | 2.1 | 7,9 | 5.4 | 20,4 | 8.2 | 31,0 | 11.0 | 41,6 | 13.9 | 52,6 |
| | 0.9 | 0,7 | 2.0 | 1,5 | 3.1 | 2,3 | 4.3 | 3,2 | 5.6 | 4,2 |
| 1000 psi (69 bar) | 2.0 | 7,6 | 5.2 | 19,7 | 8.1 | 30,7 | 10.9 | 41,3 | 13.7 | 51,9 |
| | 1.8 | 1,3 | 4.2 | 3,1 | 6.3 | 4,7 | 8.6 | 6,4 | 11.2 | 8,4 |
| 1500 psi (103 bar) | 1.9 | 7,2 | 5.1 | 19,3 | 8.0 | 30,3 | 10.8 | 40,9 | 13.6 | 51,5 |
| | 2.7 | 2,0 | 6.4 | 4,8 | 9.6 | 7,2 | 13.1 | 9,8 | 16.9 | 12,6 |
| 2000 psi (138 bar) | 1.7 | 6,4 | 5.1 | 19,3 | 7.9 | 29,9 | 10.7 | 40,5 | 13.5 | 51,1 |
| | 3.6 | 2,7 | 8.7 | 6,5 | 13.1 | 9,8 | 17.7 | 13,2 | 22.7 | 16,9 |
| 2500 psi (172 bar) | 1.6 | 6,1 | 5.0 | 18,9 | 7.8 | 29,5 | 10.6 | 40,1 | 13.4 | 50,7 |
| | 4.6 | 3,4 | 11.1 | 8,3 | 16.8 | 12,5 | 22.6 | 16,9 | 28.5 | 21,3 |
| 3000 psi (207 bar) | 1.5 | 5,7 | 4.9 | 18,5 | 7.7 | 29,1 | 10.5 | 39,7 | 13.3 | 50,3 |
| | 5.5 | 4,1 | 13.3 | 9,9 | 20.0 | 14,9 | 27.0 | 20,1 | 34.2 | 25,5 |
| rpm | 500 | 1200 | 1800 | 2400 | 3000 | | | | | |

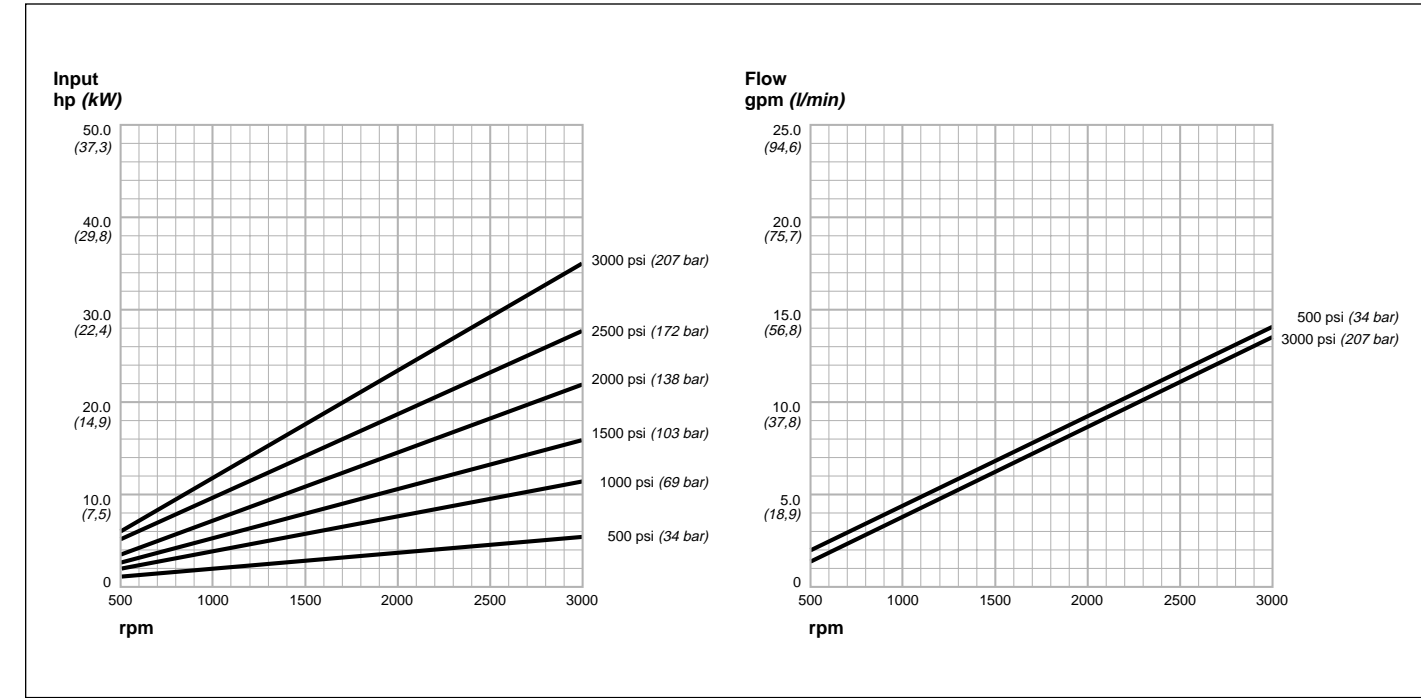

All metric values are secondary and for reference only.

K Series Hydraulic Pumps

Filtration

Recommended filtration is 10 micron nominal for maximum service life. The filter should be installed in the return line. Make sure that the filter is properly sized for your system and cleaned on a regular basis. If practical, the hydraulic system should include a warning device which signals when the filter is dirty, preventing the filter from going into a bypass condition. This will help ensure maximum component life and efficiency.

Model 129K Typical Performance Data

| Pressure | Flow Input | | | | | | | | | |
|--------------------|------------|-----|-------|------|------|------|------|------|-------|------|
| | gpm | | l/min | | hp | | kw | | Input | |
| 500 psi (34 bar) | 2.6 | 9.8 | 6.5 | 24.6 | 9.9 | 37.5 | 13.3 | 50.3 | 16.7 | 63.2 |
| | 1.0 | 0.7 | 2.4 | 1.8 | 3.6 | 2.7 | 5.0 | 3.7 | 6.6 | 4.9 |
| 1000 psi (69 bar) | 2.5 | 9.5 | 6.4 | 24.2 | 9.8 | 37.1 | 13.2 | 50.0 | 16.7 | 63.2 |
| | 2.0 | 1.5 | 4.8 | 3.6 | 7.3 | 5.4 | 9.9 | 7.4 | 13.0 | 9.7 |
| 1500 psi (103 bar) | 2.4 | 9.1 | 6.3 | 23.8 | 9.8 | 37.1 | 13.2 | 50.0 | 16.6 | 62.8 |
| | 3.1 | 2.3 | 7.4 | 5.5 | 11.2 | 8.4 | 15.0 | 11.2 | 19.9 | 14.8 |
| 2000 psi (138 bar) | 2.3 | 8.7 | 6.3 | 23.8 | 9.7 | 36.7 | 13.1 | 49.6 | 16.5 | 62.4 |
| | 4.2 | 3.1 | 10.0 | 7.5 | 15.2 | 11.3 | 20.3 | 15.1 | 26.5 | 19.8 |
| 2500 psi (172 bar) | 2.2 | 8.3 | 6.3 | 23.8 | 9.7 | 36.7 | 13.1 | 49.6 | 16.4 | 62.1 |
| | 5.3 | 4.0 | 12.7 | 9.5 | 19.4 | 14.5 | 26.0 | 19.4 | 32.8 | 24.5 |
| 3000 psi (207 bar) | 2.1 | 7.9 | 6.2 | 23.5 | 9.6 | 36.3 | 13.0 | 49.2 | 16.3 | 61.7 |
| | 6.4 | 4.8 | 15.2 | 11.3 | 23.2 | 17.3 | 31.0 | 23.1 | 39.5 | 29.5 |
| rpm | 500 | | 1200 | | 1800 | | 2400 | | 3000 | |

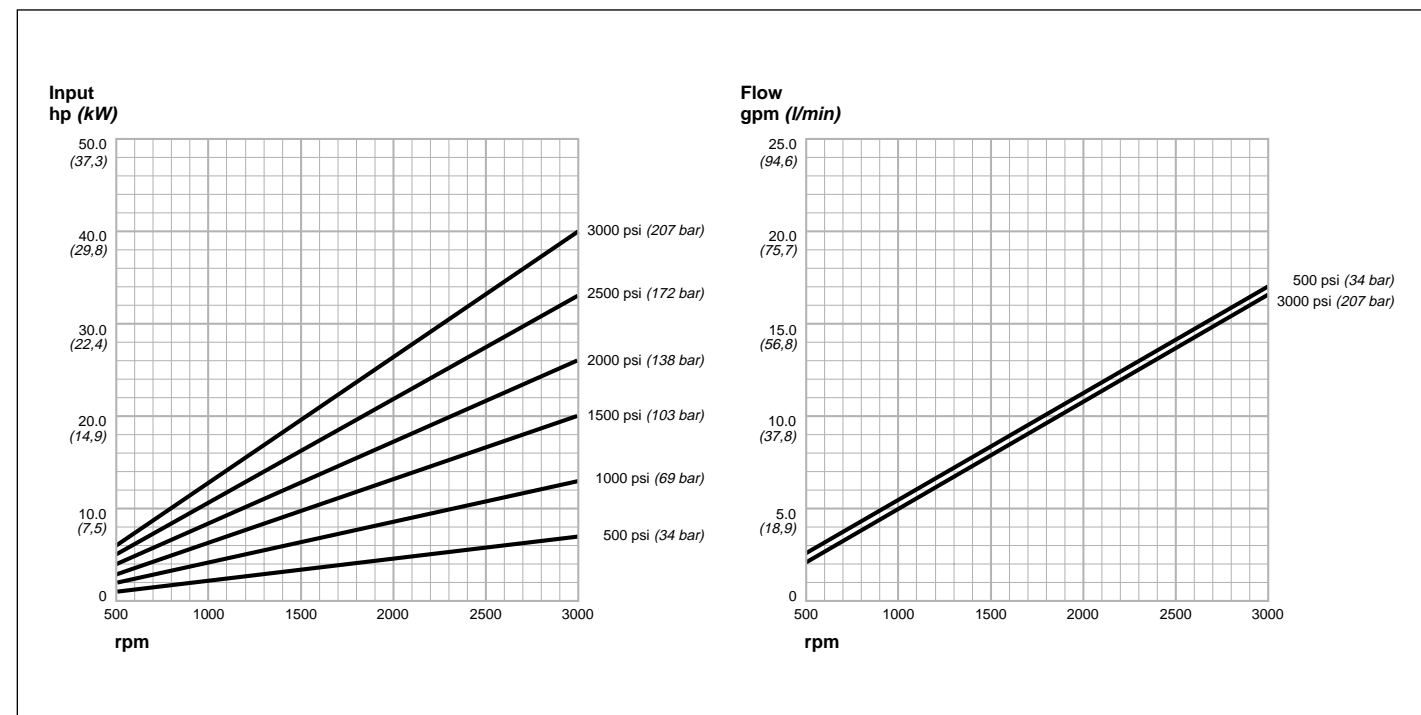

All metric values are secondary and for reference only.

K Series Hydraulic Pumps

Reservoir

The reservoir provides hydraulic system oil storage, oil deaeration, and some heat dissipation. Reservoir construction should include at least one internal baffle, creating separate chambers for system return oil and pump inlet oil. This allows return oil to deaerate and contaminants to settle out. Surplus oil would then flow over baffle to pump inlet side. Oil cleanliness is especially important at startup.

Reservoirs are ideally sized so the volume of reservoir oil is not replaced more than twice per minute. Practical considerations of space and weight, however, sometimes make this difficult on mobile equipment. A heat exchanger may be required depending on maximum system load and duty cycle.

Model 151K Typical Performance Data

| Pressure | Flow Input | | | | | | | | | |
|--------------------|------------|------|-------|------|------|------|------|------|-------|------|
| | gpm | | l/min | | hp | | kw | | Input | |
| 500 psi (34 bar) | 3.0 | 11.4 | 7.6 | 28.8 | 11.5 | 43.5 | 15.5 | 58.7 | 19.5 | 73.8 |
| | 1.1 | 0.8 | 2.7 | 2.0 | 4.2 | 3.1 | 5.8 | 4.3 | 7.5 | 5.6 |
| 1000 psi (69 bar) | 2.9 | 11.0 | 7.4 | 28.0 | 11.4 | 43.1 | 15.3 | 57.9 | 19.4 | 73.4 |
| | 2.3 | 1.7 | 5.4 | 4.0 | 8.3 | 6.2 | 11.4 | 8.5 | 14.9 | 11.1 |
| 1500 psi (103 bar) | 2.7 | 10.2 | 7.3 | 27.6 | 11.2 | 42.4 | 15.2 | 57.5 | 19.2 | 72.7 |
| | 3.5 | 2.6 | 8.3 | 6.2 | 12.5 | 9.3 | 17.2 | 12.8 | 22.3 | 16.6 |
| 2000 psi (138 bar) | 2.5 | 9.5 | 7.2 | 27.3 | 11.1 | 42.0 | 15.1 | 57.2 | 19.1 | 72.3 |
| | 4.7 | 3.5 | 11.2 | 8.4 | 17.0 | 12.7 | 23.1 | 17.2 | 29.7 | 22.1 |
| 2500 psi (172 bar) | 2.2 | 8.3 | 7.0 | 26.5 | 11.1 | 42.0 | 15.1 | 57.2 | 18.9 | 71.5 |
| | 5.9 | 4.4 | 14.3 | 10.7 | 21.7 | 16.2 | 29.3 | 21.8 | 37.0 | 27.6 |
| 3000 psi (207 bar) | 2.1 | 7.9 | 6.9 | 26.1 | 10.9 | 41.3 | 14.9 | 56.4 | 18.8 | 71.2 |
| | 7.1 | 5.3 | 17.1 | 12.8 | 25.9 | 19.3 | 35.0 | 26.1 | 44.4 | 33.1 |
| rpm | 500 | | 1200 | | 1800 | | 2400 | | 3000 | |

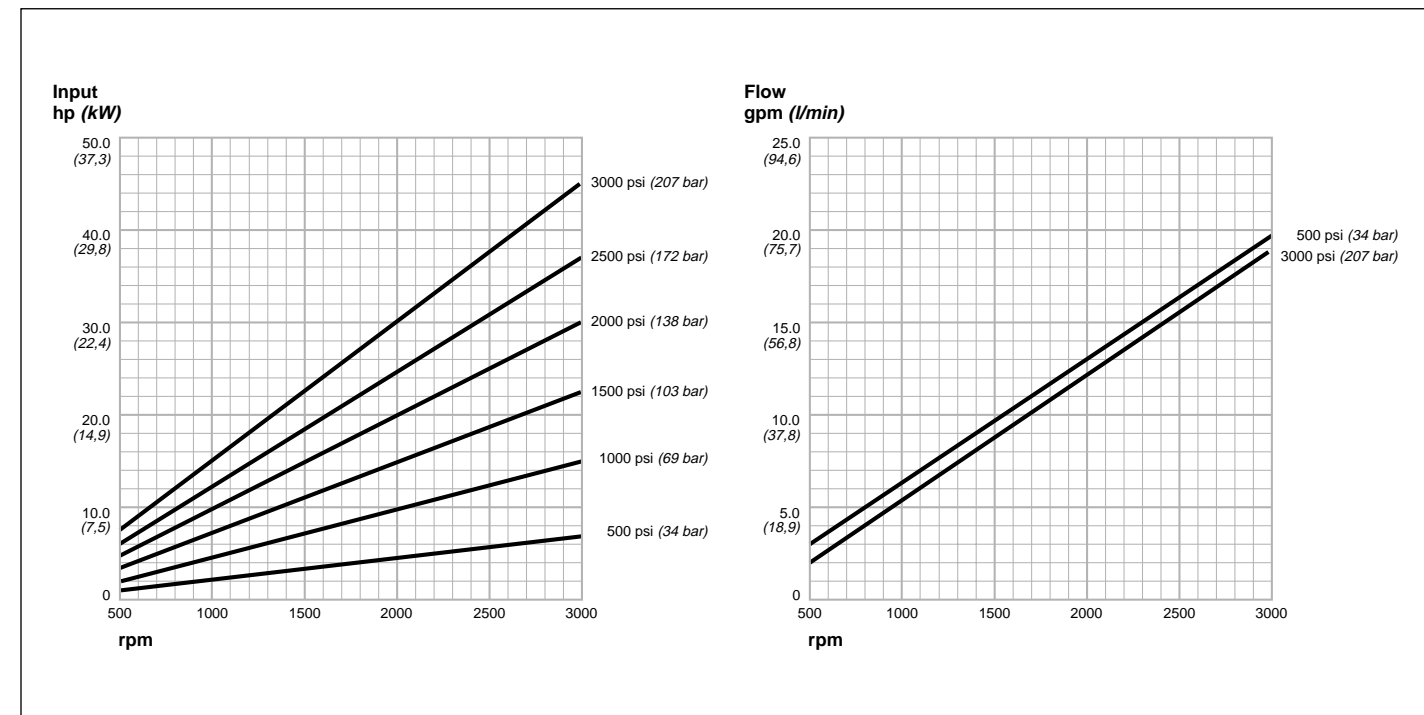

All metric values are secondary and for reference only.

K Series Hydraulic Pumps

Operating Temperatures

Pumps with nitrile rubber seals should operate at system temperatures of 180°F (82,2°C) maximum. Nitrile rubber seals can tolerate intermittent pump operation periods to 200°F (93,3°C) without damage to the pump seals. However, system temperatures exceeding 225°F (107,2°C) will cause premature seal failure and result in external leakage.

Oil in a hydraulic system that is consistently overheated will break down, forming varnish on system components, and destroying system sealing materials. Poor and erratic system operation is the usual result of an overheated system. If system temperatures are expected to consistently exceed 180°F (82,2°C), it will be necessary to place a heat exchanger in the system.

Model 194K Typical Performance Data

| Pressure | rpm | | | | | Flow | | Input | |
|--------------------|-----|------|------|------|------|-----------|-------------|-----------|-------------|
| | 500 | 1200 | 1800 | 2400 | 3000 | gpm hp | l/min kW | gpm hp | l/min kW |
| 500 psi (34 bar) | 3.9 | 9.7 | 14.9 | 19.9 | 25.0 | 14.8 | 56.4 | 75.3 | 94.6 |
| | 1.4 | 3.4 | 5.3 | 7.3 | 9.6 | 1.0 | 4.0 | 5.4 | 7.2 |
| 1000 psi (69 bar) | 3.7 | 9.5 | 14.6 | 19.7 | 24.8 | 14.0 | 55.3 | 74.6 | 93.9 |
| | 2.8 | 6.7 | 10.2 | 13.9 | 18.2 | 2.1 | 7.6 | 10.4 | 13.6 |
| 1500 psi (103 bar) | 3.4 | 9.3 | 14.4 | 19.5 | 24.5 | 12.9 | 54.5 | 73.8 | 92.7 |
| | 4.2 | 10.1 | 15.3 | 20.7 | 27.2 | 3.1 | 11.4 | 15.4 | 20.3 |
| 2000 psi (138 bar) | 3.2 | 9.1 | 14.3 | 19.4 | 24.3 | 12.1 | 54.1 | 73.4 | 92.0 |
| | 5.7 | 13.5 | 20.6 | 27.8 | 36.2 | 4.3 | 15.4 | 20.7 | 27.0 |
| 2500 psi (172 bar) | 2.8 | 8.9 | 14.1 | 19.3 | 24.2 | 10.6 | 53.4 | 73.0 | 91.6 |
| | 7.1 | 17.1 | 26.1 | 35.2 | 44.5 | 5.3 | 19.5 | 26.2 | 33.2 |
| 3000 psi (207 bar) | 2.6 | 8.7 | 13.9 | 19.1 | 23.9 | 9.8 | 52.6 | 72.3 | 90.5 |
| | 8.5 | 20.4 | 31.1 | 41.9 | 53.5 | 6.3 | 23.2 | 31.2 | 39.9 |
| rpm | 500 | 1200 | 1800 | 2400 | 3000 | | | | |

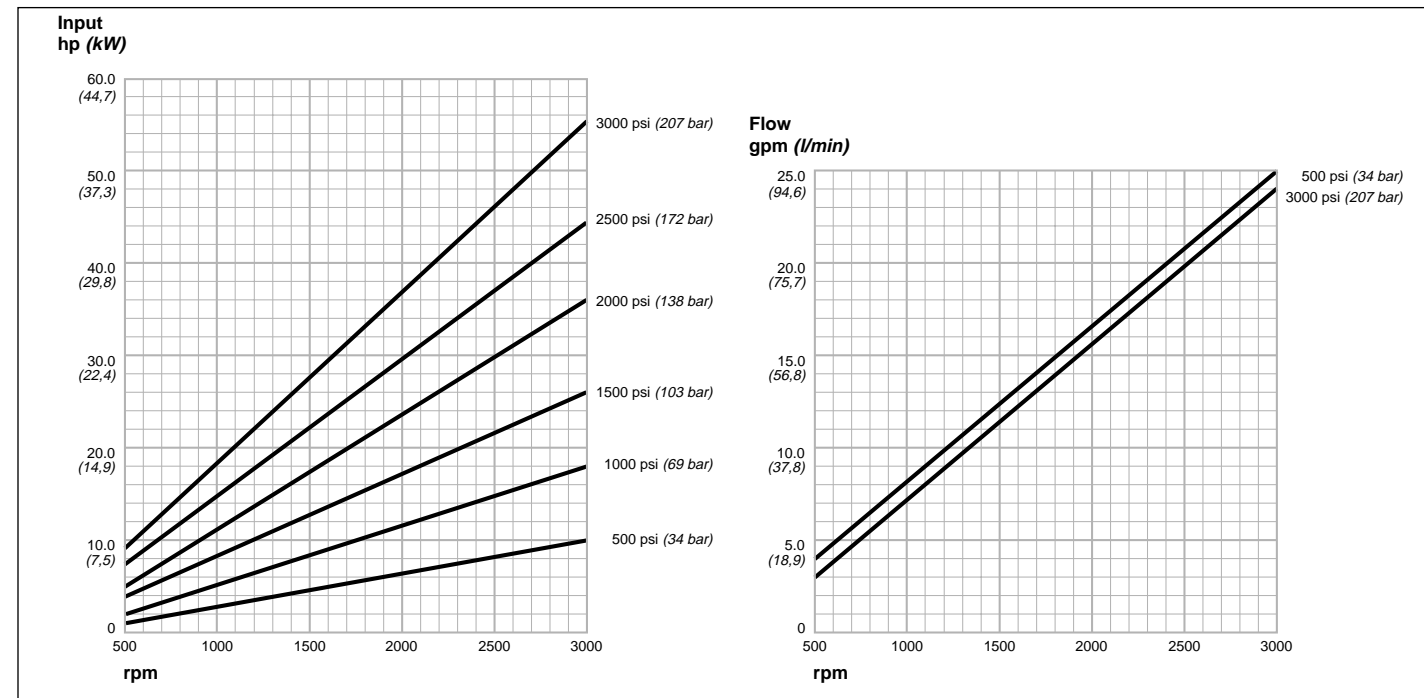

All metric values are secondary and for reference only.

K Series Hydraulic Pumps

Drives

K Series hydraulic pumps can be mounted in either direct or indirect drive configurations. The pump mount and drive should be designed to minimize axial and radial loads on the pump shaft. The preferred method is direct mounting using a flex coupler. The coupler may be omitted if .004" (0,10 mm) total indicator

reading is maintained between the pilot mounting diameter and the drive shaft powering the pump. For indirect drives, consult QCC.

Model 237K Typical Performance Data

| Pressure | rpm | | | | | Flow | | Input | |
|--------------------|------|------|------|------|------|-----------|-------------|-----------|-------------|
| | 500 | 1200 | 1800 | 2400 | 3000 | gpm hp | l/min kW | gpm hp | l/min kW |
| 500 psi (34 bar) | 4.8 | 12.0 | 18.2 | 24.4 | 30.6 | 18.2 | 68.9 | 92.3 | 115.8 |
| | 1.7 | 4.2 | 6.5 | 8.9 | 11.7 | 1.3 | 4.8 | 6.6 | 8.7 |
| 1000 psi (69 bar) | 4.6 | 11.8 | 18.0 | 24.2 | 30.3 | 17.4 | 68.1 | 91.6 | 114.7 |
| | 3.4 | 8.0 | 12.2 | 16.8 | 22.0 | 2.5 | 9.1 | 12.5 | 16.4 |
| 1500 psi (103 bar) | 4.4 | 11.7 | 17.8 | 24.0 | 30.1 | 16.7 | 67.4 | 90.8 | 113.9 |
| | 5.0 | 11.9 | 18.1 | 24.8 | 32.3 | 3.7 | 13.5 | 18.5 | 24.1 |
| 2000 psi (138 bar) | 4.1 | 11.5 | 17.7 | 23.9 | 29.9 | 15.5 | 67.0 | 90.5 | 113.2 |
| | 6.7 | 16.0 | 24.2 | 32.9 | 42.4 | 5.0 | 18.0 | 24.5 | 31.6 |
| 2500 psi (172 bar) | 3.8 | 11.3 | 17.6 | 23.8 | 29.8 | 14.4 | 66.6 | 90.1 | 112.8 |
| | 8.4 | 20.2 | 30.5 | 41.1 | 52.3 | 6.3 | 22.7 | 30.6 | 39.0 |
| 3000 psi (207 bar) | 3.6 | 11.2 | 17.4 | 23.6 | 29.5 | 13.6 | 65.9 | 89.3 | 111.7 |
| | 10.1 | 24.1 | 36.3 | 49.1 | 62.6 | 7.5 | 27.1 | 36.6 | 46.7 |
| rpm | 500 | 1200 | 1800 | 2400 | 3000 | | | | |

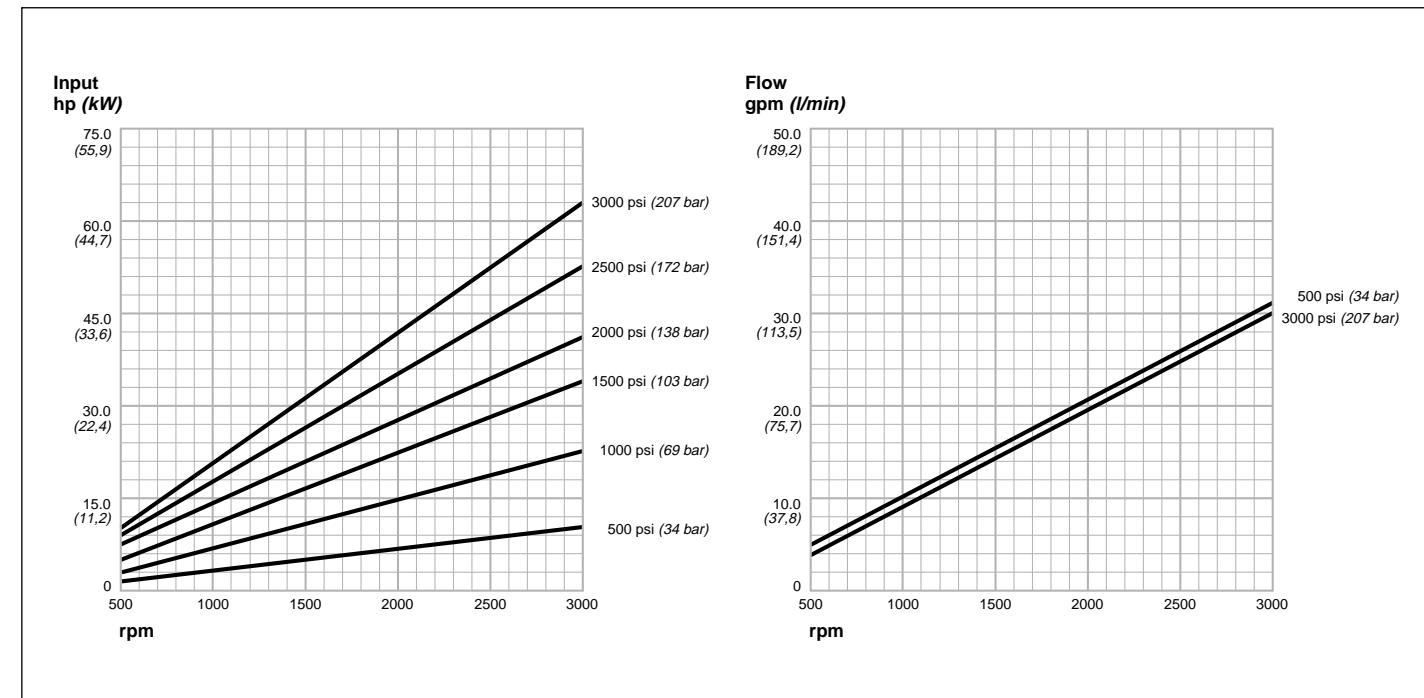

All metric values are secondary and for reference only.

K Series Hydraulic Pumps

System Plumbing

The major objective in the specification of tubing and hose sizes is to limit maximum oil velocity. This results in quieter system operation, consistent operating temperature, and a reduction of heat through the elimination of pressure drops. To avoid pump cavitation, maximum inlet line flow should not exceed 10 feet per second (3,04 m/sec). Inlet vacuum should not exceed 5" Hg (127 mm) at the normal

operating temperature. Continuous operation at vacuums in excess of 5" Hg (127 mm) will cause premature unit failure. On cold starts, a vacuum of 10" Hg (254 mm) can be tolerated for short durations. Higher inlet vacuums than 10" Hg (254 mm) shorten pump life by creating heat and excessive pressure on the pump. Pump discharge lines should have flow velocities under 20 feet per second (6,10 m/sec).

Model 280K Typical Performance Data

| Pressure | rpm | | | | | Flow Input | |
|--------------------|------------|-------------|-------------|-------------|-------------|------------|-------------|
| | 500 | 1200 | 1800 | 2400 | 3000 | gpm hp | l/min kW |
| 500 psi (34 bar) | 5.7 | 14.3 | 21.5 | 28.8 | 36.0 | 28.8 | 109,0 |
| | 2.0 | 5.0 | 7.6 | 10.7 | 14.3 | 8,0 | 10,7 |
| 1000 psi (69 bar) | 5.5 | 14.1 | 21.4 | 28.6 | 35.7 | 28.6 | 108,2 |
| | 4.0 | 9.6 | 14.6 | 19.9 | 26.8 | 14,8 | 20,0 |
| 1500 psi (103 bar) | 5.3 | 13.9 | 21.2 | 28.4 | 35.5 | 28.4 | 107,5 |
| | 5.9 | 14.2 | 21.6 | 29.5 | 38.8 | 22,0 | 29,9 |
| 2000 psi (138 bar) | 5.1 | 13.7 | 21.0 | 28.3 | 35.3 | 28.3 | 107,1 |
| | 7.9 | 19.0 | 28.7 | 39.0 | 50.2 | 29,1 | 37,4 |
| 2500 psi (172 bar) | 4.8 | 13.6 | 21.0 | 28.1 | 35.1 | 28.1 | 106,4 |
| | 9.9 | 23.8 | 36.0 | 48.6 | 60.7 | 36,2 | 45,3 |
| 3000 psi (207 bar) | 4.6 | 13.4 | 20.8 | 27.9 | 34.9 | 27.9 | 105,6 |
| | 11.9 | 28.4 | 43.0 | 58.0 | 73.0 | 43,3 | 54,4 |
| rpm | 500 | 1200 | 1800 | 2400 | 3000 | | |

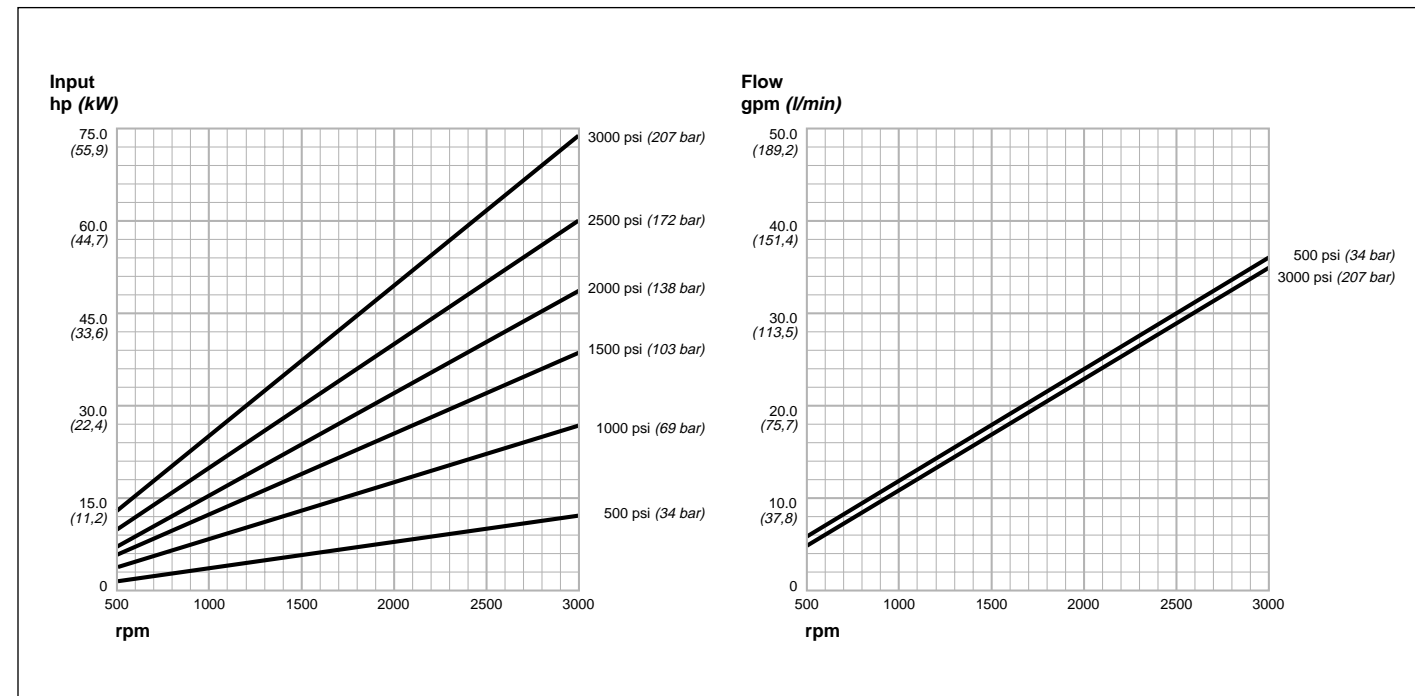

All metric values are secondary and for reference only.

K Series Hydraulic Pumps

Cavitation

Cavitation problems can be the result of excessive air in the oil, high inlet vacuum, improper reservoir construction and placement, or operation exceeding rated operating speed. Hydraulic oil normally has some dissolved air. Air leaks on the pump inlet side, however, will raise the air content substantially. Since air is more compressible than oil, air bubbles will collapse (or implode) when pressurized,

causing severe stress on hydraulic system components. As the air content increases, resultant damage to the system also increases. High inlet vacuum, often caused by restrictions or improper reservoir configuration, are another source of cavitation. Operation of a pump at higher than rated speeds increases inlet vacuum and can result in cavitation as well.

Model 323K Typical Performance Data

| Pressure | rpm | | | | | Flow Input | |
|--------------------|------------|-------------|-------------|-------------|-------------|------------|-------------|
| | 500 | 1200 | 1800 | 2400 | 3000 | gpm hp | l/min kW |
| 500 psi (34 bar) | 6.6 | 16.5 | 24.9 | 33.1 | 41.3 | 33.1 | 125,3 |
| | 2.3 | 5.6 | 8.8 | 12.6 | 17.3 | 9,4 | 12,9 |
| 1000 psi (69 bar) | 6.4 | 16.3 | 24.7 | 32.9 | 41.0 | 32.9 | 124,5 |
| | 4.8 | 11.3 | 17.4 | 24.4 | 33.1 | 18,2 | 24,7 |
| 1500 psi (103 bar) | 6.2 | 16.1 | 24.5 | 32.7 | 40.7 | 32.7 | 123,8 |
| | 7.2 | 17.1 | 26.0 | 35.9 | 47.4 | 26,8 | 35,3 |
| 2000 psi (138 bar) | 6.0 | 16.0 | 24.3 | 32.5 | 40.5 | 32.5 | 123,0 |
| | 9.5 | 22.9 | 34.7 | 47.0 | 60.1 | 35,0 | 44,8 |
| 2500 psi (172 bar) | 5.7 | 15.8 | 24.2 | 32.3 | 40.3 | 32.3 | 122,2 |
| | 11.7 | 28.8 | 43.5 | 57.8 | 71.4 | 43,1 | 53,2 |
| 3000 psi (207 bar) | 5.5 | 15.6 | 24.0 | 32.1 | 40.0 | 32.1 | 121,5 |
| | 14.2 | 34.5 | 52.1 | 69.4 | 86.4 | 51,8 | 64,4 |
| rpm | 500 | 1200 | 1800 | 2400 | 3000 | | |

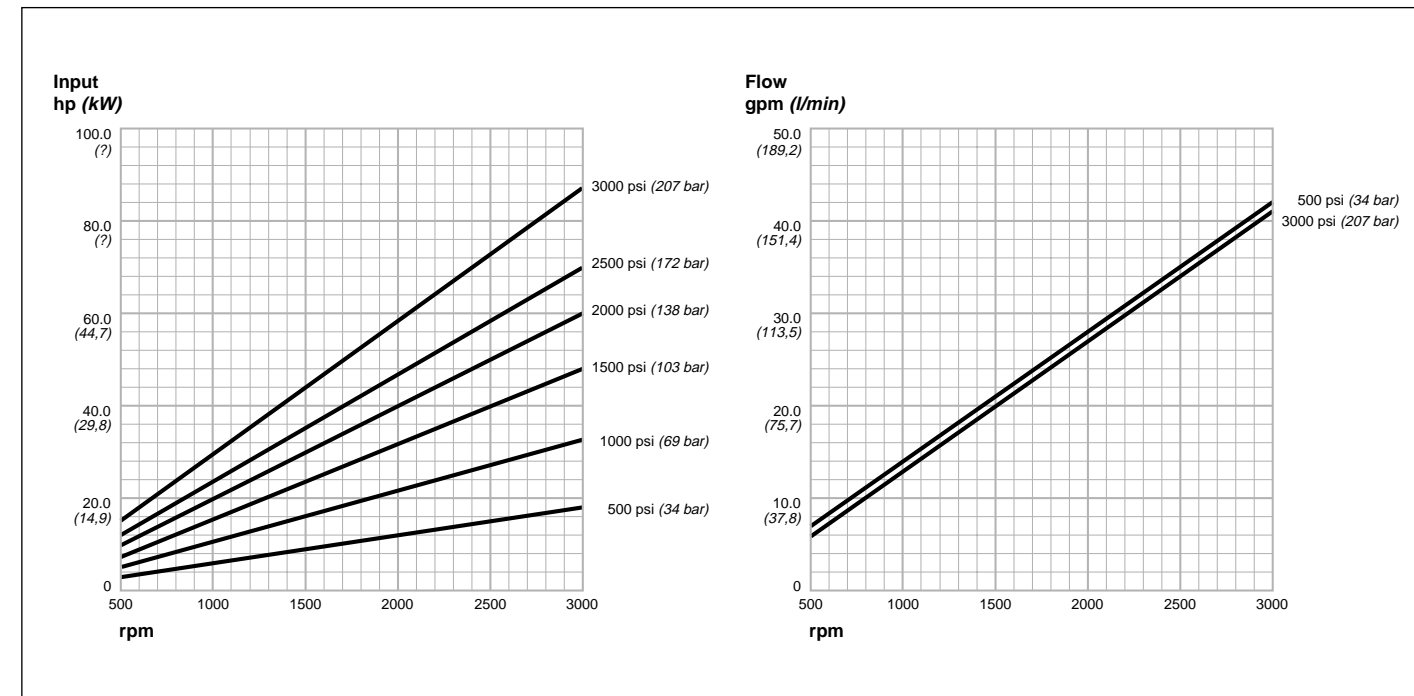

All metric values are secondary and for reference only.

K Series Hydraulic Pumps

Operating Speeds and Pressure Ratings

A hydraulic pump's speed rating is determined by the ability of the pump to fill with oil without cavitating, with a given inlet pressure and oil viscosity. Maximum speed for K Series pumps is limited to 3000 rpm, based on operation at sea level using SAE oil with a viscosity of 175 SUS at 120°F (48,9°C). Minimum speed for the K Series is 500 rpm. This is the normal minimum speed at which the pump will operate continuously at rated pressure.

Consult QCC for operation outside these limits.

K Series pumps are designed to operate continuously at the rated pressures shown on page 6. In most applications this should also be considered maximum relief valve setting. Lower operating pressures will extend the life of the unit. Maximum operating pressures decrease in the higher displacement pumps.

Model 388K Typical Performance Data

| Pressure | Flow | | | | |
|--------------------|------|-------|------|------|-------|
| | gpm | l/min | hp | kw | Input |
| 500 psi (34 bar) | 8.0 | 30,3 | 19.9 | 75,3 | 30.0 |
| | 3.0 | 2,2 | 7.5 | 5,6 | 11.9 |
| 1000 psi (69 bar) | 7.8 | 29,5 | 19.7 | 74,6 | 29.8 |
| | 5.7 | 4,3 | 13.9 | 10,4 | 21.5 |
| 1500 psi (103 bar) | 7.5 | 28,4 | 19.5 | 73,8 | 29.6 |
| | 8.4 | 6,3 | 20.1 | 15,0 | 30.9 |
| 2000 psi (138 bar) | 7.2 | 27,3 | 19.3 | 73,0 | 29.2 |
| | 11.1 | 8,3 | 26.5 | 19,8 | 40.6 |
| 2500 psi (172 bar) | 6.9 | 26,1 | 19.0 | 71,9 | 29.0 |
| | 13.9 | 10,4 | 33.2 | 24,8 | 50.3 |
| rpm | 500 | 1200 | 1800 | 2275 | 2750 |

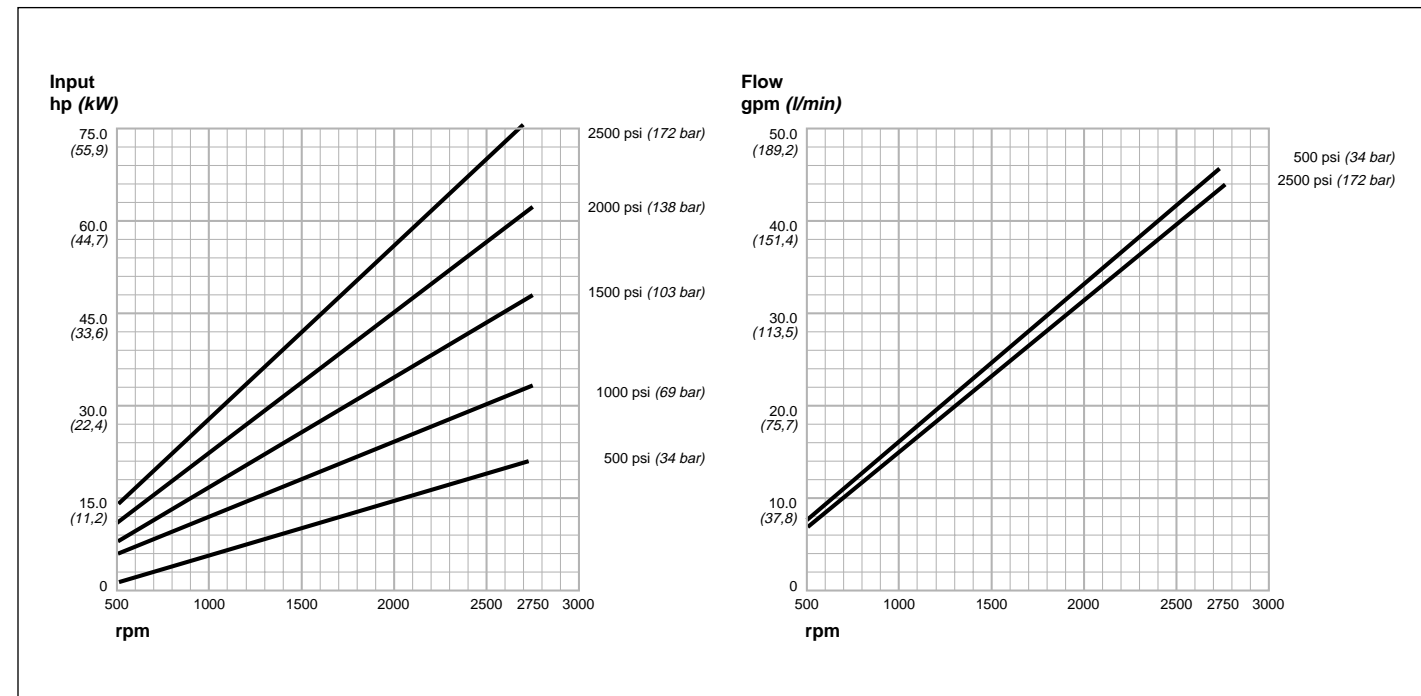

All metric values are secondary and for reference only.

MK Series Hydraulic Motors

Specifications

| Model | Displacement | in ³ /rev (cm ³ /rev) | Gear Width | in. (mm) |
|-------|--------------|---|------------|----------|
| M129K | 1.29 | (21,14) | 0.60 | (15,24) |
| M151K | 1.51 | (24,74) | 0.70 | (17,78) |
| M194K | 1.94 | (31,79) | 0.90 | (22,86) |
| M237K | 2.37 | (38,84) | 1.10 | (27,94) |
| M280K | 2.80 | (45,88) | 1.30 | (33,02) |
| M323K | 3.23 | (52,93) | 1.50 | (38,10) |
| M388K | 3.88 | (63,58) | 1.80 | (45,72) |

Note: Theoretical pump delivery in gpm (l/min) is determined by multiplying displacement-in³/rev (cm³/rev)-by desired pump rpm and dividing by 231 (1000).

MK motors have a pressure-balanced design for high volumetric and mechanical efficiencies. They feature three-piece construction with two lightweight, high strength aluminum alloy bearing housings combined with a high tensile cast iron center gear plate. Integral gears and shafts are made of heat-treated alloy steel. Standard features include straight keyed shafts, heavy-duty sleeve bearings, double lip, high pressure nitrile rubber seals; and side SAE O-ring type ports.

| | |
|-------------------------------------|---|
| Operating Pressures | 2500 psi (172 bar) continuous |
| Recommended Operating Speeds | To 3000 rpm. M388K to 2750 rpm. See performance curves. |
| Maximum Back Pressure | With standard high pressure seal — 10 psi (0,7 bar). With optional high pressure shaft seal — 50 psi (3,4 bar). Lower back pressure will extend seal life and improve efficiency. |
| Mounting | SAE 2-bolt code "101-2" ("B"). |
| Shafts | 1.00" (25,40 mm) diameter straight keyed shaft, optional .86" (21,84 mm) - 13-tooth splined shafts, standard. 1.00" (25,40 mm) - 15-tooth splined shaft, optional. Other shafts available upon request. |
| Shaft Rotation | Clockwise. Counterclockwise. (When viewed from shaft end) |
| Seals | High pressure nitrile rubber. |
| Bearings | Heavy-duty, low friction PTFE-lined bronze sleeve bushings. |
| Porting | SAE O-ring side location, standard. End or combination location, optional. |
| Weight | 13 to 22 pounds (5,9 to 10,0 kg). |

All metric values are secondary and for reference only.

MK Series Hydraulic Motors

Dimensions

(CCW Shaft Rotation Shown)

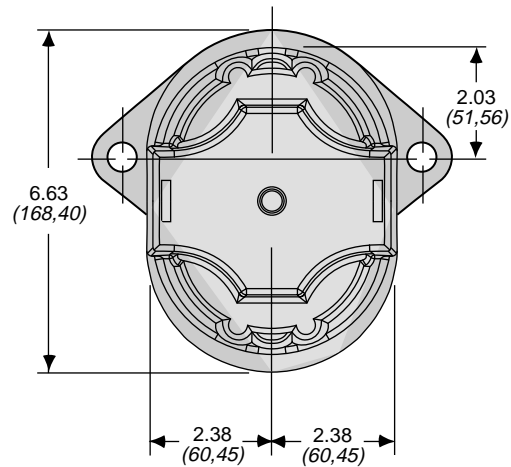
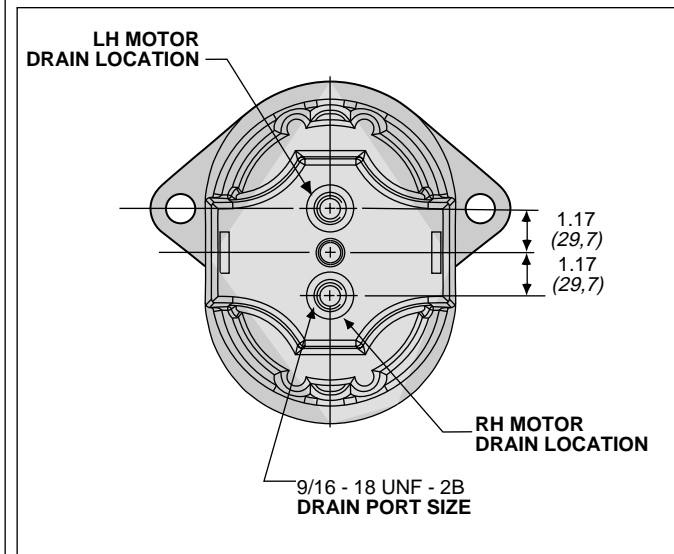
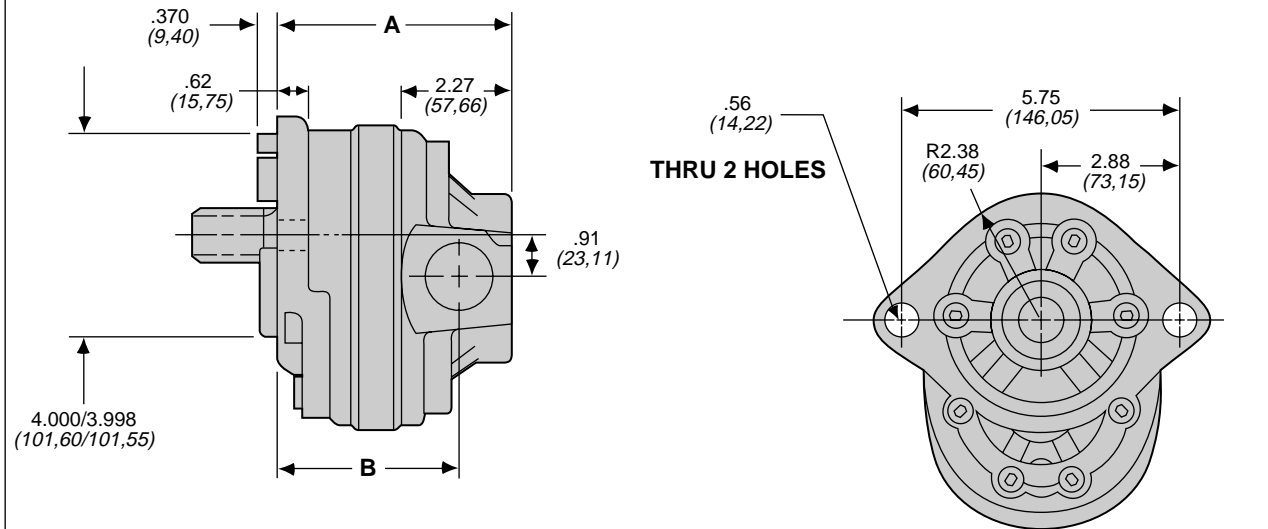

| Type | Dimension "A" | Dimension "B" | Type | Dimension "A" | Dimension "B" |
|-------|---------------|---------------|-------|---------------|---------------|
| M129K | 4.36 (110,74) | 3.34 (84,84) | M280K | 5.06 (128,52) | 4.04 (102,62) |
| M151K | 4.46 (113,28) | 3.44 (87,38) | M323K | 5.26 (133,60) | 4.24 (107,70) |
| M194K | 4.66 (118,36) | 3.64 (92,46) | M388K | 5.56 (141,22) | 4.54 (115,32) |
| M237K | 4.86 (123,44) | 3.84 (97,54) | | | |

Dimensions shown: inches (mm)

All metric values are secondary and for reference only.

MK Series Hydraulic Motors

Filtration

Operating Temperatures

Recommended filtration is 10 micron nominal for maximum motor service life. Make sure that the filter is properly sized for the system and cleaned on a regular basis. If practical, the hydraulic system should include a warning device which signals when the filter element is dirty, preventing the filter from going into a bypass condition. This will help ensure maximum component life and efficiency.

MK motors with high pressure nitrile rubber shaft seal should normally operate at system temperatures of 180°F (82,2°C)

maximum. Nitrile rubber seals can tolerate intermittent motor operation periods to 200°F (93,3°C) without damage to the seal material. However, system temperatures exceeding 225°F (107,2°C) will cause premature seal failure and result in external leakage.

An optional seal, the double lip, high pressure fluoroelastomer shaft seal provides higher temperature operation and can be used with fluids not compatible with nitrile rubber seals.

Model M129K Typical Performance Data

| Pressure | Input Flow | | | | Torque | | | |
|--------------------|--------------|---------------|--------------|---------------|--------------|---------------|--------------|---------------|
| | gpm lb-in | l/min daNm | gpm lb-in | l/min daNm | gpm lb-in | l/min daNm | gpm lb-in | l/min daNm |
| 500 psi (34 bar) | 5.7 | 21,6 | 10.2 | 38,6 | 13.6 | 51,5 | 17.0 | 64,3 |
| | 56.0 | 0,6 | 51.6 | 0,6 | 50.5 | 0,6 | 51.5 | 0,6 |
| 1000 psi (69 bar) | 6.0 | 22,7 | 10.5 | 39,7 | 13.8 | 52,2 | 17.2 | 65,1 |
| | 113.4 | 1,3 | 110.4 | 1,2 | 107.7 | 1,2 | 104.8 | 1,2 |
| 1500 psi (103 bar) | 6.2 | 23,5 | 10.7 | 40,5 | 14.1 | 53,4 | 17.4 | 65,9 |
| | 168.9 | 1,9 | 169.5 | 1,9 | 167.6 | 1,9 | 163.8 | 1,9 |
| 2000 psi (138 bar) | 6.4 | 24,2 | 10.9 | 41,3 | 14.3 | 54,1 | 17.6 | 66,6 |
| | 222.5 | 2,5 | 228.9 | 2,6 | 230.2 | 2,6 | 228.6 | 2,6 |
| 2500 psi (172 bar) | 6.6 | 25,0 | 11.1 | 42,0 | 14.5 | 54,9 | 17.8 | 67,4 |
| | 274.2 | 3,1 | 288.5 | 3,3 | 295.5 | 3,3 | 299.2 | 3,4 |
| rpm | 1000 | 1800 | 2400 | 3000 | | | | |

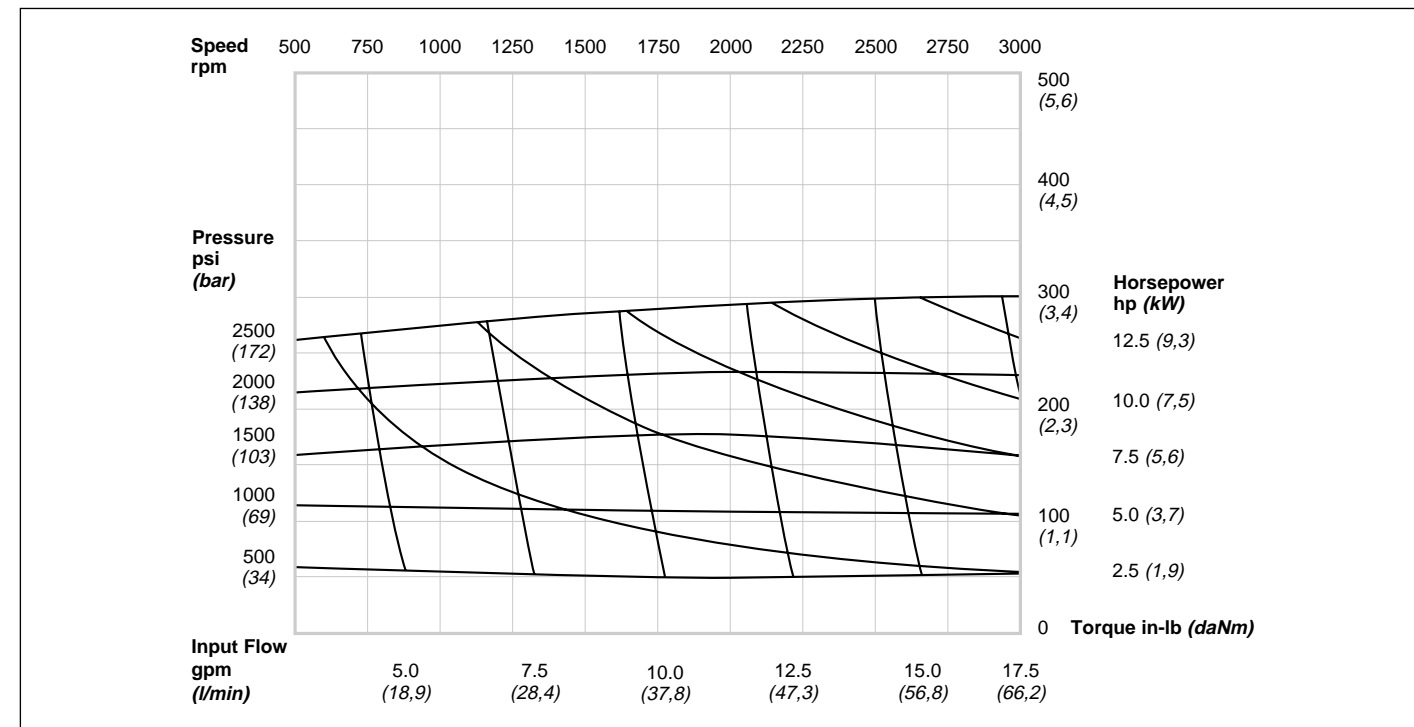

All metric values are secondary and for reference only.

MK Series Hydraulic Motors

Operating Pressure Ratings

Oil in a hydraulic system that is consistently overheated will break down, forming varnish on system components, and destroying system sealing materials. Poor and erratic system operation is the usual result of an overheated system. If system temperatures are expected to consistently exceed 180°F (82,2°C), a heat exchanger placed in the return line may be necessary.

Operating Speeds

MK motors are designed to operate continuously at pressures to 2500 psi (172 bar).

MK motors have a maximum operating speed range up to 3000 rpm, based on operation at sea level using SAE oil with a viscosity of 175 SUS at 120°F (48,9°C). Actual limits for each displacement can be found in the motor performance curves. Minimum speed is 500 rpm. This is the normal minimum speed at which the motor will operate continuously at rated pressure. Consult QCC for operation outside these limits.

Model M151K Typical Performance Data

| Pressure | Input Flow | | | |
|--------------------|--------------|---------------|--------------|---------------|
| | gpm lb-in | l/min daNm | gpm lb-in | l/min daNm |
| 500 psi (34 bar) | 6.7 | 25,4 | 11.9 | 45,0 |
| | 70.9 | 0,8 | 63.2 | 0,7 |
| 1000 psi (69 bar) | 6.9 | 26,1 | 12.2 | 46,2 |
| | 146.2 | 1,7 | 142.6 | 1,6 |
| 1500 psi (103 bar) | 7.2 | 27,3 | 12.4 | 46,9 |
| | 219.9 | 2,5 | 220.8 | 2,5 |
| 2000 psi (138 bar) | 7.4 | 28,0 | 12.6 | 47,7 |
| | 292.1 | 3,3 | 297.8 | 3,4 |
| 2500 psi (172 bar) | 7.5 | 28,4 | 12.8 | 48,4 |
| | 362.8 | 4,1 | 373.6 | 4,2 |
| rpm | 1000 | 1800 | 2400 | 3000 |

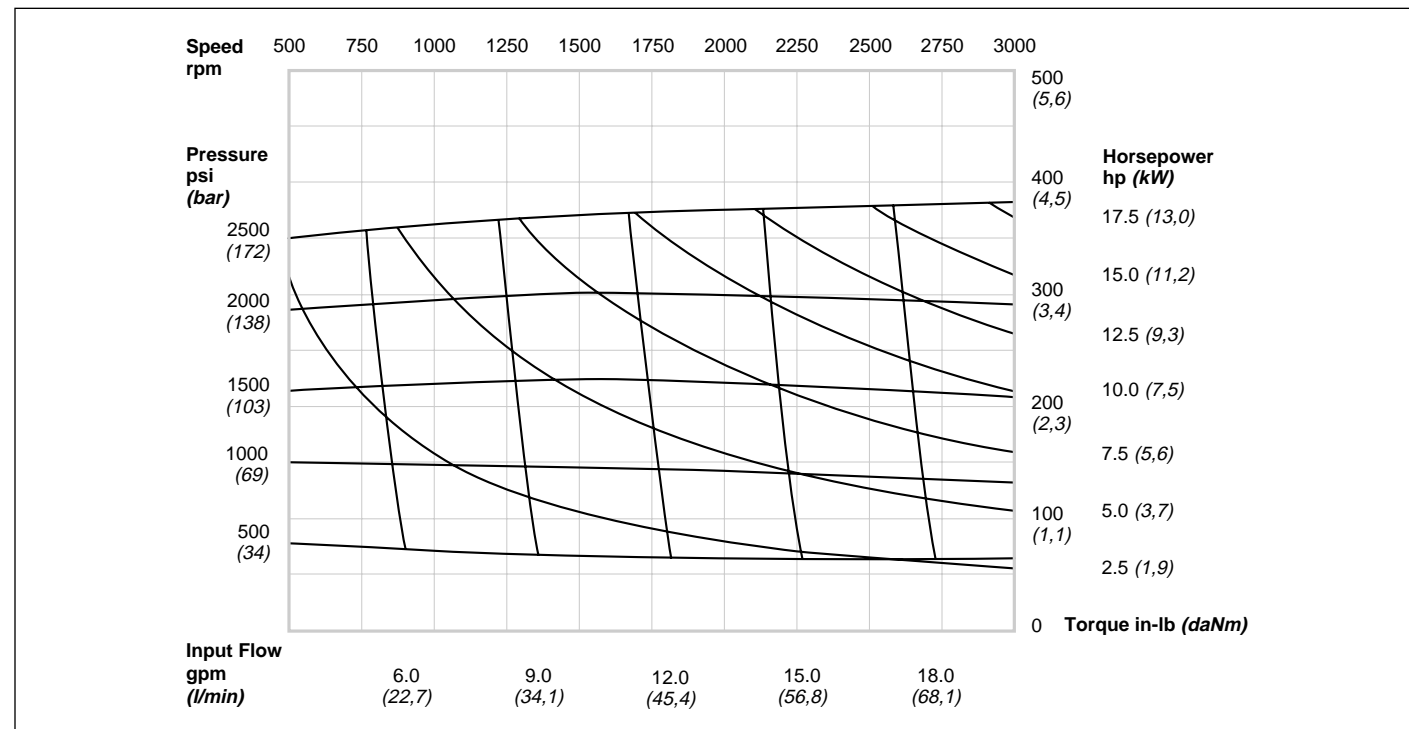

All metric values are secondary and for reference only.

MK Series Hydraulic Motors

System Plumbing

Undersized or restricted return lines can cause excessive back pressure on the motor shaft seal. Excessively high back pressures can shorten shaft seal life and cause efficiency loss through heat buildup. To avoid excessive back pressure, the return line should be sized such that flow does not exceed 10 psi (0,7 bar), for a motor with the standard seal.

A motor with the optional high pressure seal can tolerate back pressure to 50 psi (3,4 bar). Motors may be internally or externally drained.

Model M194K Typical Performance Data

| Pressure | Input Flow | | | |
|--------------------|--------------|---------------|--------------|---------------|
| | gpm lb-in | l/min daNm | gpm lb-in | l/min daNm |
| 500 psi (34 bar) | 8.5 | 32,2 | 15.3 | 57,9 |
| | 99.2 | 1,1 | 86.9 | 1,0 |
| 1000 psi (69 bar) | 8.8 | 33,3 | 15.5 | 58,7 |
| | 211.2 | 2,4 | 205.0 | 2,3 |
| 1500 psi (103 bar) | 9.1 | 34,4 | 15.8 | 59,8 |
| | 321.3 | 3,6 | 319.5 | 3,6 |
| 2000 psi (138 bar) | 9.3 | 35,2 | 16.0 | 60,6 |
| | 429.3 | 4,9 | 430.4 | 4,9 |
| 2500 psi (172 bar) | 9.4 | 35,6 | 16.2 | 61,3 |
| | 535.4 | 6,0 | 537.8 | 6,1 |
| rpm | 1000 | 1800 | 2400 | 3000 |

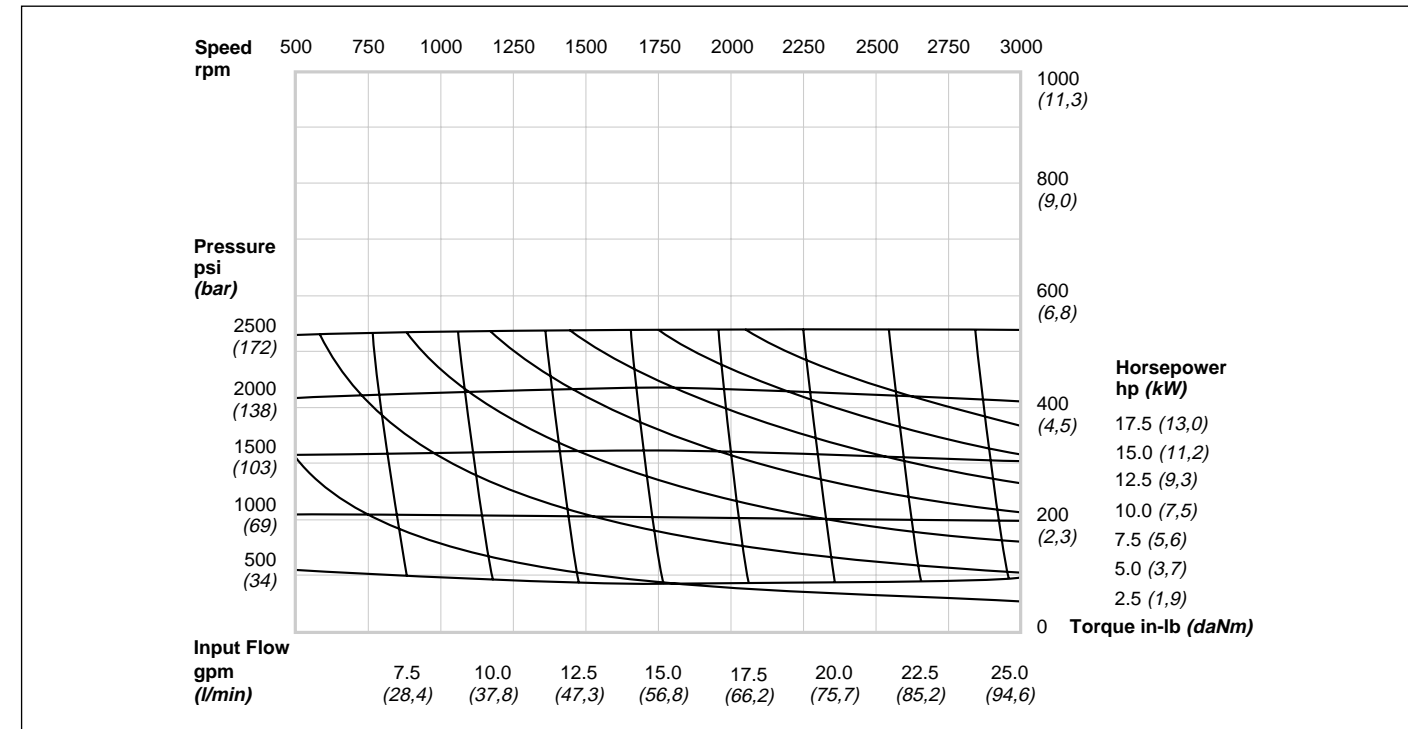

All metric values are secondary and for reference only.

MK Series Hydraulic Motors

Performance Curve Use

Performance curves shown for MK motors combine 5 related variables: pressure, speed, input flow, output torque, and horsepower output. If any two variables are known or assumed, the others can be determined. Compare the curves for all models and select the one which provides the best performance at desired speed and torque. Example: the application requires a motor producing 700 lb-inches (7,9 daNm) of torque at 1350 rpm. Using the M237K performance curves as an

example, discover the values for psi (bar), gpm (l/min), and hp. Find and mark the intersection of 1350 rpm and 700 lb-inches (7,9 daNm) on the curve; the value of the remaining variables can be found by interpolation. In this case they would be 2500 psi (172 bar), 15 gpm (56,8 l/min) and 15 hp. Examine the motor curves for each displacement and choose the motor most suitable for the desired application.

Model M237K Typical Performance Data

| Pressure | Input Flow | | | |
|--------------------|--------------|---------------|--------------|---------------|
| | gpm lb-in | l/min daNm | gpm lb-in | l/min daNm |
| 500 psi (34 bar) | 10.4 | 39,4 | 18.6 | 70,4 |
| | 24.8 | 93,9 | 30.9 | 117,0 |
| 1000 psi (69 bar) | 128.4 | 1,5 | 111.4 | 1,3 |
| | 112.7 | 1,3 | 126.2 | 1,4 |
| 1500 psi (103 bar) | 10.7 | 40,5 | 18.9 | 71,5 |
| | 25.0 | 94,6 | 31.2 | 118,1 |
| 2000 psi (138 bar) | 277.7 | 3,1 | 266.7 | 3,0 |
| | 257.3 | 2,9 | 246.9 | 2,8 |
| 2500 psi (172 bar) | 11.0 | 41,6 | 19.1 | 72,3 |
| | 25.3 | 95,8 | 31.4 | 118,8 |
| rpm | 423.6 | 4,8 | 416.4 | 4,7 |
| | 402.4 | 4,5 | 381.0 | 4,3 |
| 1000 | 11.2 | 42,4 | 19.3 | 73,0 |
| | 25.5 | 96,5 | 31.6 | 119,6 |
| 1800 | 566.1 | 6,4 | 560.7 | 6,3 |
| | 548.2 | 6,2 | 528.5 | 6,0 |
| 2400 | 11.3 | 42,8 | 19.5 | 73,8 |
| | 25.6 | 96,9 | 31.8 | 120,4 |
| 3000 | 705.1 | 8,0 | 699.4 | 7,9 |
| | 694.6 | 7,8 | 689.4 | 7,8 |

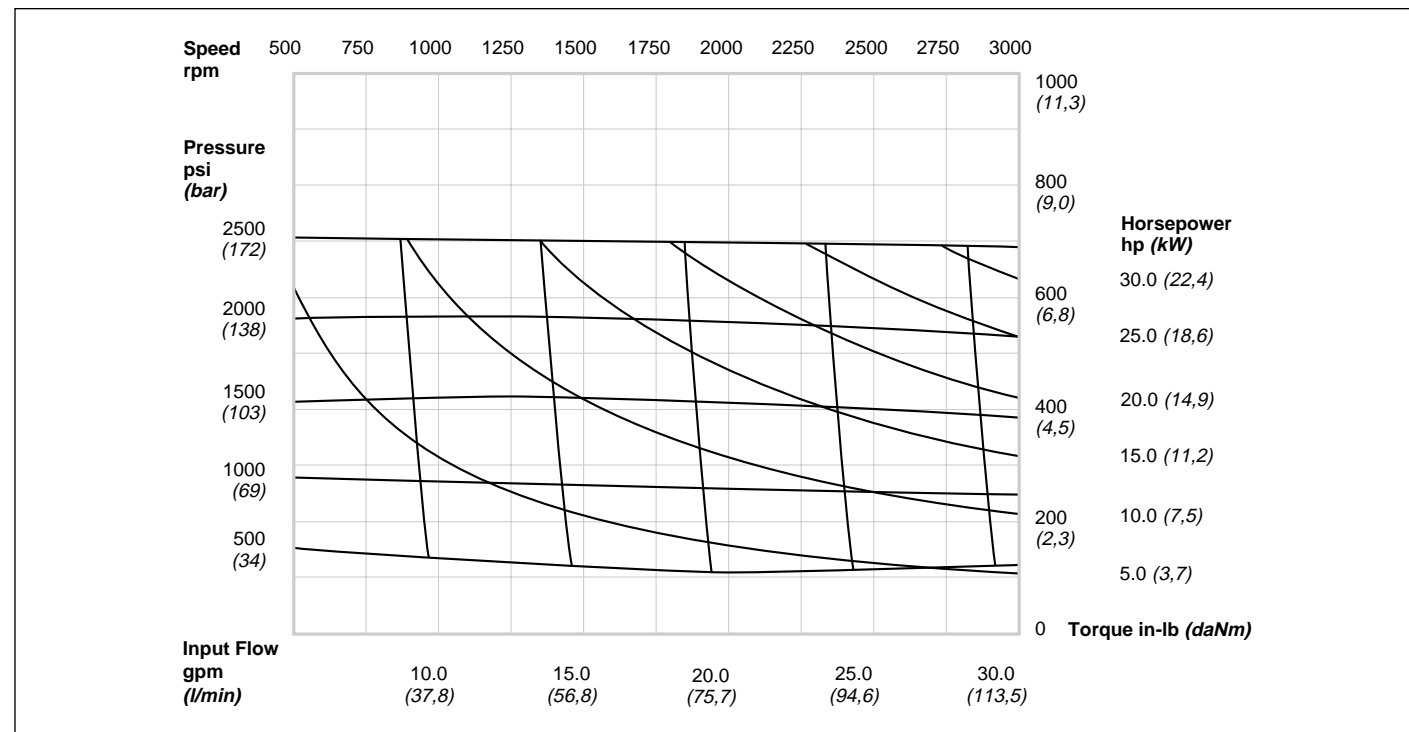

All metric values are secondary and for reference only.

MK Series Hydraulic Motors

Hydraulic Fluids

Hydraulic fluid performs three basic functions. First, it provides efficient transfer of power from the pump to the actuators. Second, the fluid provides lubrication and surface protection to the working parts. The use of petroleum-based fluids with rust and oxidation inhibitors remains the principal choice for most hydraulic systems. Third, the fluid acts to transfer heat to maintain a consistent system temperature operating range.

Viscosity is the most important property of a hydraulic fluid. It measures how the fluid resists flow. Thick, dense oil has high viscosity; thin oil has low viscosity. Ideally, the fluid should have a viscosity of 100 to 180 SUS (21-39 cSt) at operating temperature, with 7500 SUS (1618 cSt) maximum viscosity for low temperature startup condition.

Model M280K Typical Performance Data

| Pressure | Input Flow | | | |
|--------------------|--------------|---------------|--------------|---------------|
| | gpm lb-in | l/min daNm | gpm lb-in | l/min daNm |
| 500 psi (34 bar) | 12.2 | 46,2 | 21.9 | 82,9 |
| | 29.2 | 110,5 | 36.5 | 138,1 |
| 1000 psi (69 bar) | 160.4 | 1,8 | 135.5 | 1,5 |
| | 134.5 | 1,5 | 148.6 | 1,7 |
| 1500 psi (103 bar) | 12.5 | 47,3 | 22.2 | 84,0 |
| | 29.4 | 111,3 | 36.7 | 138,9 |
| 2000 psi (138 bar) | 345.6 | 3,9 | 327.2 | 3,7 |
| | 312.8 | 3,5 | 297.9 | 3,4 |
| 2500 psi (172 bar) | 12.8 | 48,4 | 22.4 | 84,8 |
| | 29.7 | 112,4 | 36.9 | 139,7 |
| rpm | 525.5 | 5,9 | 511.7 | 5,8 |
| | 491.4 | 5,6 | 462.5 | 5,2 |
| 1000 | 13.0 | 49,2 | 22.6 | 85,5 |
| | 29.9 | 113,2 | 37.1 | 140,4 |
| 1800 | 700.2 | 7,9 | 688.8 | 7,8 |
| | 670.0 | 7,6 | 642.5 | 7,3 |
| 2400 | 13.2 | 50,0 | 22.8 | 86,3 |
| | 30.0 | 113,5 | 37.2 | 140,8 |
| 3000 | 869.7 | 9,8 | 858.6 | 9,7 |
| | 848.8 | 9,6 | 837.7 | 9,5 |

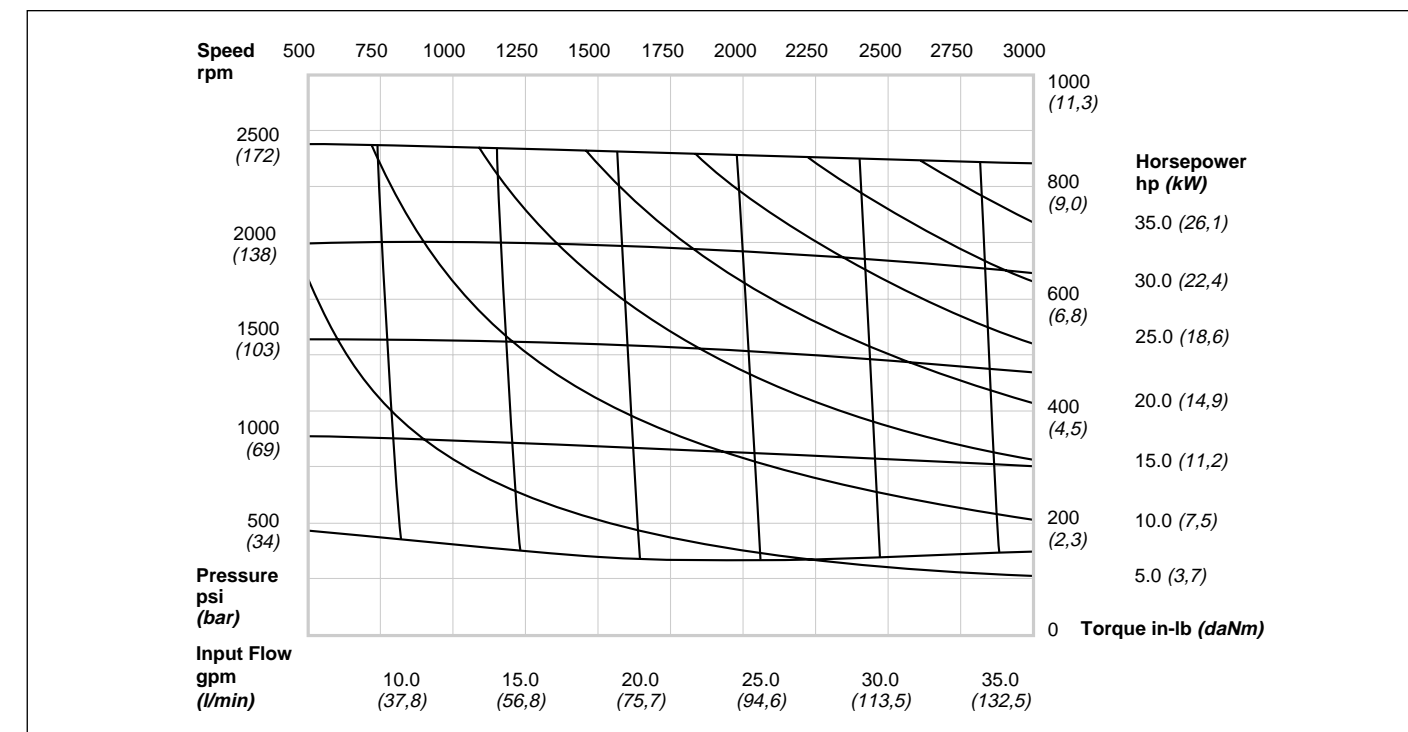

All metric values are secondary and for reference only.

MK Series Hydraulic Motors

Hydraulic Fluids (continued)

Viscosity index measures how the viscosity of the hydraulic fluid changes with temperature. A high viscosity index indicates that the hydraulic fluid will have almost the same viscosity at high and low temperatures. Fluids with viscosities that vary widely with temperatures changes have a low viscosity index. Because of the wide range of operating temperatures encountered, hydraulic pumps should use fluids with a high viscosity index.

Pour point is the lowest rated temperature at which a hydraulic fluid will flow. Because hydraulic pumps are often used on mobile equipment that may be exposed to very low outside temperatures, a low pour point is very important. Ideally, the fluid pour point should be at least 20°F (11,1°C) below the lowest expected outside temperature.

Model M323K Typical Performance Data

| Pressure | gpm | | l/min | | Input Flow | | Torque | |
|--------------------|--------|------|--------|------|------------|-------|--------|-------|
| | lb-in | daNm | lb-in | daNm | lb-in | daNm | lb-in | daNm |
| 500 psi (34 bar) | 14.1 | 53,4 | 25.3 | 95,8 | 33.6 | 127,2 | 42.0 | 159,0 |
| | 197.4 | 2,2 | 158.5 | 1,8 | 146.1 | 1,7 | 148.2 | 1,7 |
| 1000 psi (69 bar) | 14.4 | 54,5 | 25.5 | 96,5 | 33.8 | 127,9 | 42.2 | 159,7 |
| | 414.8 | 4,7 | 386.5 | 4,4 | 363.9 | 4,1 | 340.3 | 3,8 |
| 1500 psi (103 bar) | 14.6 | 55,3 | 25.7 | 97,3 | 34.0 | 128,7 | 42.3 | 160,1 |
| | 625.6 | 7,1 | 605.3 | 6,8 | 578.6 | 6,5 | 542.0 | 6,1 |
| 2000 psi (138 bar) | 14.9 | 56,4 | 25.9 | 98,0 | 34.2 | 129,4 | 42.5 | 160,9 |
| | 829.6 | 9,4 | 815.1 | 9,2 | 790.2 | 8,9 | 753.4 | 8,5 |
| 2500 psi (172 bar) | 15.1 | 57,2 | 26.1 | 98,8 | 34.3 | 129,8 | 42.6 | 161,2 |
| | 1026.9 | 11,6 | 1015.6 | 11,5 | 998.6 | 11,3 | 974.4 | 11,0 |
| rpm | 1000 | | 1800 | | 2400 | | 3000 | |

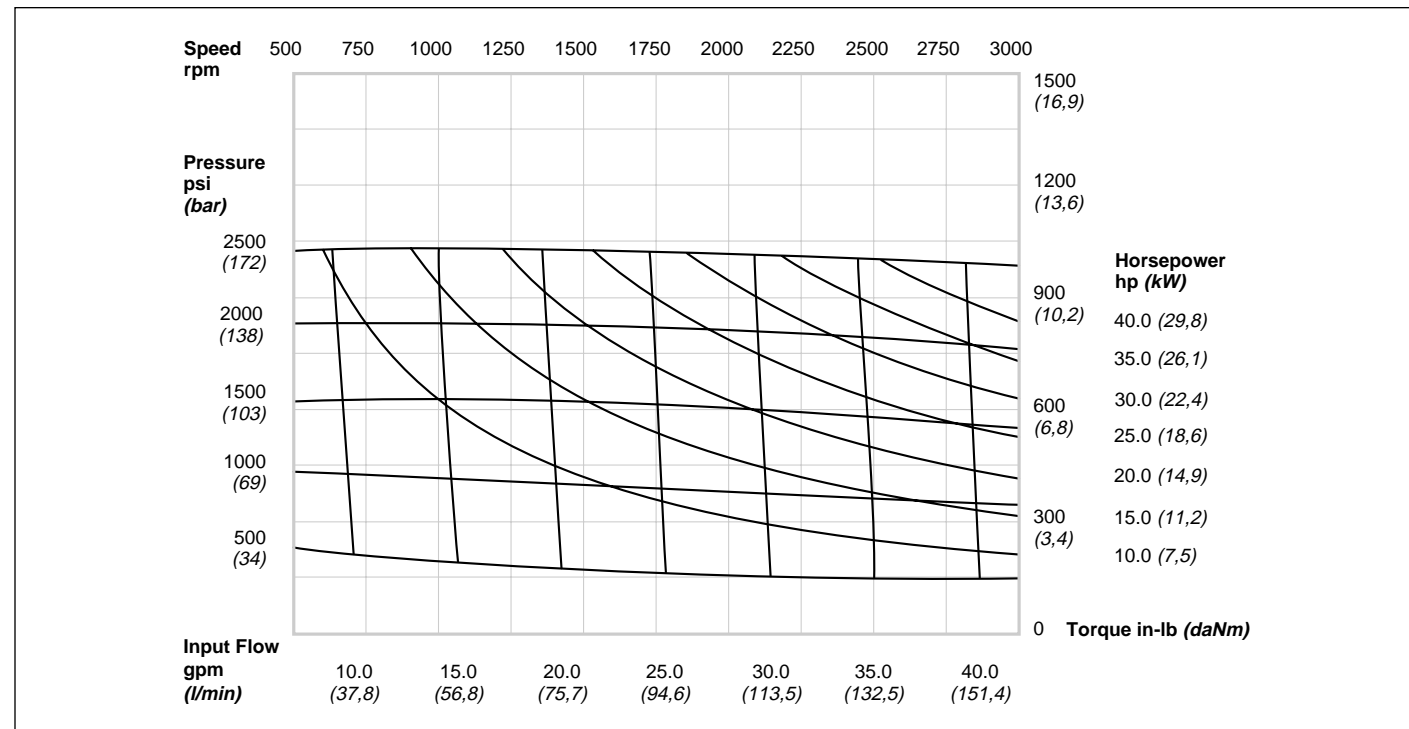

All metric values are secondary and for reference only.

MK Series

Hydraulic Fluids (continued)

Hydraulic fluid in everyday use is constantly stressed by temperature changes, high pressures, oxidation, and contamination. A hydraulic fluid with **good stability characteristics** will resist premature breakdown. At the same time, keeping the hydraulic fluid **clean** is probably the most essential aspect for ensuring the reliable performance of the system. Contamination is the leading cause of hydraulic system breakdowns. The system should always be filtered and the element should be regularly cleaned or replaced. When the

fluid needs replacing, be sure to use a good grade of new, clean fluid.

The hydraulic fluid must be **compatible** with nitrile rubber sealing components. In addition, a good grade of hydraulic fluid will **contain additives** to help control wear, oxidation and foaming.

Please consult QCC before using any non-petroleum base or fire resistant fluids which may require special seal materials.

Model M388K Typical Performance Data

| Pressure | gpm | | l/min | | Input Flow | | Torque | |
|--------------------|--------|------|--------|-------|------------|-------|--------|------|
| | lb-in | daNm | lb-in | daNm | lb-in | daNm | lb-in | daNm |
| 500 psi (34 bar) | 17.0 | 64,3 | 30.3 | 114,7 | 46.2 | 174,9 | | |
| | 243.4 | 2,7 | 198.4 | 2,2 | 145.0 | 1,6 | | |
| 1000 psi (69 bar) | 17.3 | 65,5 | 30.6 | 115,8 | 46.5 | 176,0 | | |
| | 520.3 | 5,9 | 468.1 | 5,3 | 406.2 | 4,6 | | |
| 1500 psi (103 bar) | 17.6 | 66,6 | 30.9 | 117,0 | 46.8 | 177,1 | | |
| | 784.8 | 8,9 | 733.6 | 8,3 | 672.7 | 7,6 | | |
| 2000 psi (138 bar) | 17.9 | 67,7 | 31.2 | 118,1 | 47.1 | 178,3 | | |
| | 1037.1 | 11,7 | 994.8 | 11,2 | 944.5 | 10,7 | | |
| 2500 psi (172 bar) | 21.3 | 80,6 | 34.2 | 129,4 | 51.7 | 195,7 | | |
| | 1380.0 | 15,6 | 1300.0 | 14,7 | 1275.0 | 14,4 | | |
| rpm | 1000 | | 1800 | | 2750 | | | |

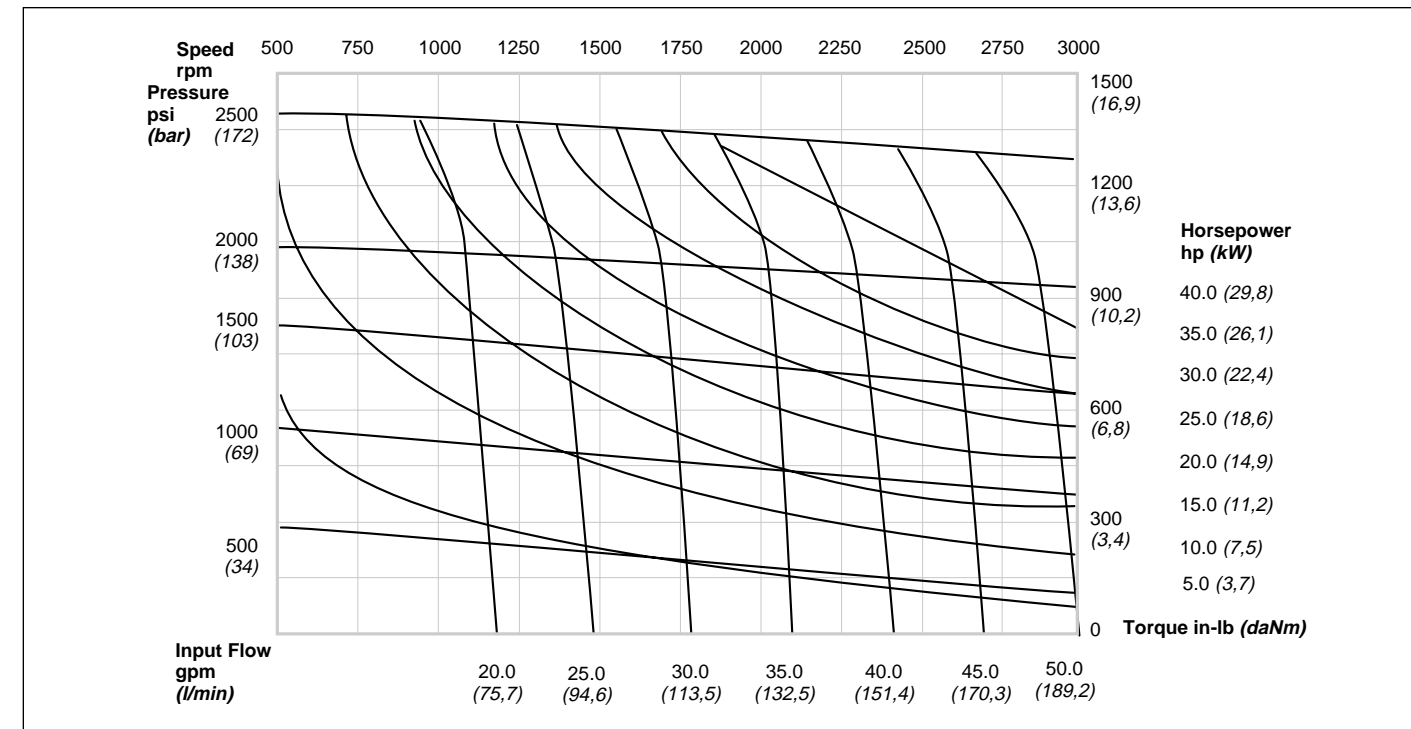

All metric values are secondary and for reference only.

Order Code Analysis

For Single Pumps and Motors

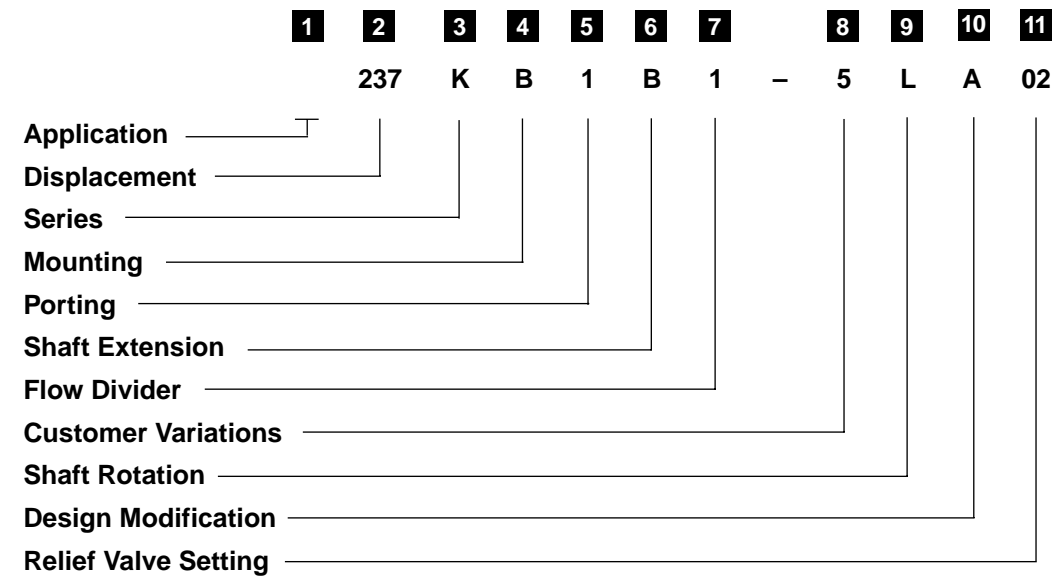

For Multi-Circuit Pumps

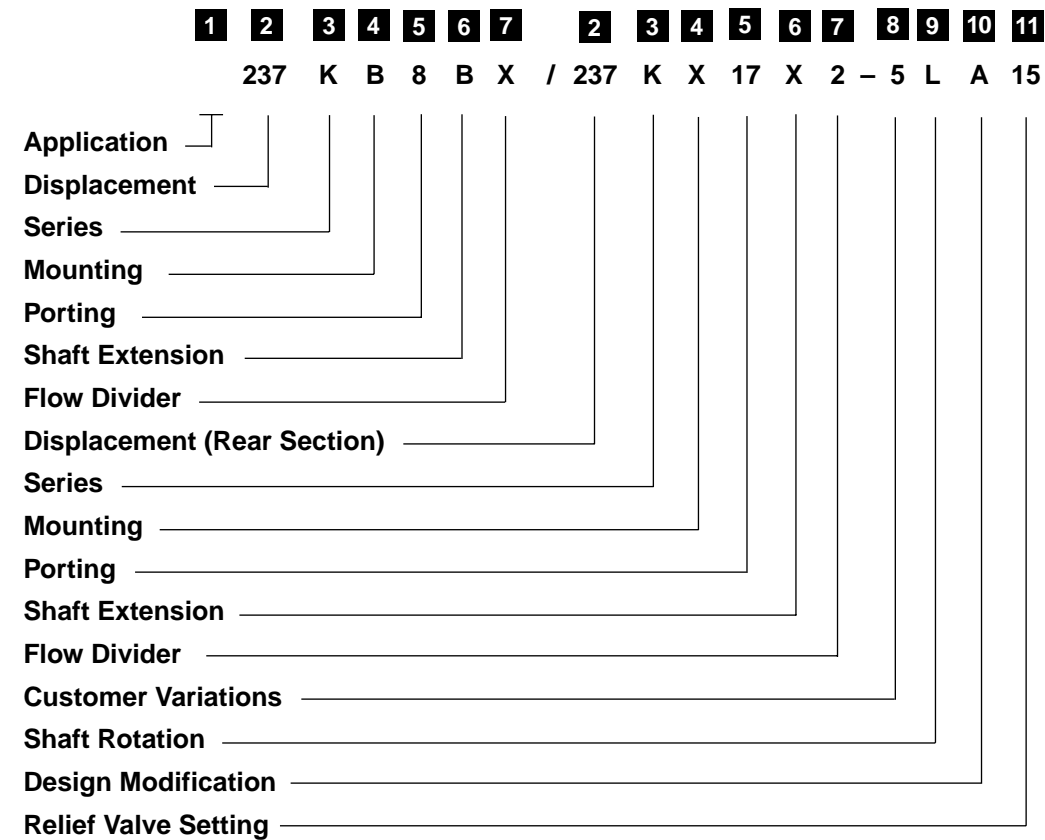

All metric values are secondary and for reference only.

Order Code Analysis

| | |
|-------------|--------------------------|
| 1 | Application |
| Omit | No letter indicates pump |
| M | Motor |

| | | | |
|--------------------------|---|----------------------------|---------|
| 2 | Displacement | | |
| Displacement Code | Displacement in³/rev (cm³/rev) | Gear Width in. (mm) | |
| 086 | .86 (14,09) | 0.40 | (10,16) |
| 108 | 1.08 (17,70) | 0.50 | (12,70) |
| 129 | 1.29 (21,14) | 0.60 | (15,24) |
| 151 | 1.51 (24,74) | 0.70 | (17,78) |
| 194 | 1.94 (31,79) | 0.90 | (22,86) |
| 237 | 2.37 (38,84) | 1.10 | (27,94) |
| 280 | 2.80 (45,88) | 1.30 | (33,02) |
| 323 | 3.23 (52,93) | 1.50 | (38,10) |
| 388 | 3.88 (63,58) | 1.80 | (45,72) |

| | |
|----------|-----------------|
| 3 | Series K |
|----------|-----------------|

| | |
|----------|--|
| 4 | Mounting |
| X | No mounting – applies to rear section of dual assemblies and center and rear sections of triple assemblies |
| B | SAE 2-bolt code "101-2" (SAE "B") |
| D | Gear plate mount – (2) 5/8 - 11 UNC-2B tapped holes on 3.50" (88,9 mm) centers located in gear plate |
| G | Gear plate mount – (2) 5/8 - 18 UNF-2B tapped holes on 2.25" (57,2 mm) centers located in gear plate |

| | |
|-----------|---|
| 5 | Porting |
| | Pump Without Flow Divider (Unless Specified, Porting is in Cover) |
| 1 | 1 5/8 - 12 SAE straight thread (inlet) tank, 1 5/16 - 12 SAE straight thread (outlet) pressure – (sides) |
| 8 | 1 5/8 - 12 SAE straight thread (inlet) tank, 1 5/16 - 12 SAE straight thread (outlet) pressure – (sides of bearing plate) |
| 42 | 1 1/4" SAE split flange (inlet) tank, 1" SAE split flange (outlet) pressure – (sides) |
| 92 | 1 5/16 - 12 tank, 1 1/16 - 12 press (sides) and 9/16 - 18 ext. drain (end CCW from tank port) |
| | Pump With Flow Divider |
| 10 | 1 5/8 - 12 SAE straight thread (inlet) tank – (side), 3/4 - 16 SAE straight thread (outlet) priority – (end), 7/8 - 14 SAE straight thread (outlet) secondary – (end) |

All metric values are secondary and for reference only.

Order Code Analysis

| 6 | Shaft Extension |
|----|--|
| X | No shaft extension – applies to rear section of dual assemblies and center and rear sections of triple assemblies |
| A | .864" (26,95 mm) dia. spline, 13-tooth – 1.75" (44,5 mm) extension |
| B | 1.00" (25,40 mm) dia. straight keyed shaft – 2.50" (63,5 mm) extension with .25" (6,4 mm) x 1.50" (38,1 mm) long squar key |
| C | 1.00" (25,40 mm) dia. straight keyed shaft – 2.00" (50,8 mm) extension with .25" (6,4 mm) x 1.00" (25,40 mm) long square key, 1.19 (30,2 mm) long flat |
| D | 1.00" (25,40 mm) nom. dia. 15-tooth spline – 1.75" (44,5 mm) extension |
| F | .864" (21,95 mm) dia. spline, 13-tooth – 1.62" (41,15 mm) extension |
| W | .875" (22,23 mm) dia. shaft – 2.50" (63,5 mm) extension with #15 woodruff key (thru shaft) |
| AS | .875" (22,23 mm) dia. straight keyed shaft – 1.62" (41,15 mm) extension with .25" (6,4 mm) x 1.00" (25,40 mm) long square key-SAE 22-1 ("B") |

| 7 | Flow Divider |
|----|-----------------------------------|
| X | Standard cover (No flow divider) |
| 01 | Priority flow 2.0 gpm (7,6 l/min) |
| 02 | Priority flow 4.0 gpm (15 l/min) |
| 03 | Priority flow 6.0 gpm (23 l/min) |
| 04 | Priority flow 8.0 gpm (30 l/min) |
| 05 | Priority flow 10.0 gpm (38 l/min) |
| 12 | Priority flow 3.0 gpm (11 l/min) |
| 13 | Priority flow 5.0 gpm (19 l/min) |

| 8 | Customer Variations |
|------|------------------------------|
| Omit | No number indicates standard |
| 1 | Special thru shaft |
| 5 | High pressure shaft seal |

| 9 | Shaft Rotation (viewed from shaft end) |
|---|--|
| L | Left hand (Counterclockwise) |
| R | Right hand (Clockwise) |

10 Design Modification – Consult QCC

11 Relief Valve Setting
Standard models with integral relief valve will be set at 1500 psi (103 bar). The code numbers represent valve settings multiplied by 1/100. Consult QCC for other settings and availability.

All metric values are secondary and for reference only.

Notes

