

QCC Integrated Actuator For Stanadyne "D" Series Injection Pump Model DYNA 70025

— Factory Approved by Stanadyne —

General

The QCC Integral Governor System for Stanadyne "D" Series* injection pumps has been designed in close cooperation with Stanadyne. Through this cooperation a uniquely simple integrated governor is now available.

QCC has taken a proven rotary actuator and built it into a new cover design for Stanadyne "D" Series injection pumps. This new integrated approach eliminates all brackets and external linkage. No internal parts to the injection pump need to be added or replaced.

The actuator design utilizes the principle of variable reluctance. This simple design of a proportional electric solenoid has a rotating armature whose magnetic force is proportional to input coil current.

The integrated actuator and injection pump housing is very easy to install. Simply remove the existing cover and install the new cover. Along with the standard model (DYNC-70025-000-0-12/24), a completely sealed model (DYNC-70025-001-0-12/24) is also available. Pollutants from contaminated fuel can cause the actuator to bind and hinder the engine governing. For those contaminated fuel applications, the completely sealed model prevents pollutants from entering the actuator and causing erratic governing.

Standard Features

- 1 All Electric
- 1 Fast Response
- 1 Compact
- 1 Precise Repeatability
- 1 No External Linkage
- 1 No Mounting Bracket
- 1 Spring Return to Shut Off

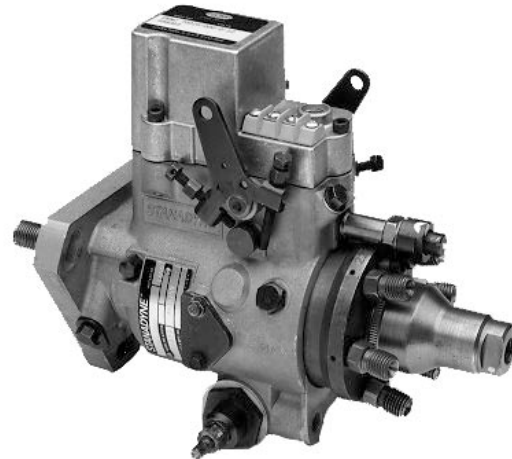

Standard Models

DYNC-70025-000-0-12/24
DYNC-70025-200-0-12/24

Actuator is available with flying lead connector, which mates with Packard weatherpak 2 way connector with female sleeves, part number 1201 5792.

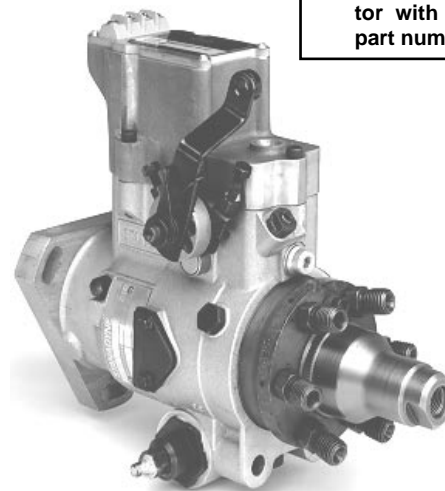

Sealed Model

DYNC-70025-001-0-12/24



Installation Dimensions — DYNC-70025-000-0-12/24 & DYNC-70025-200-0-12/24

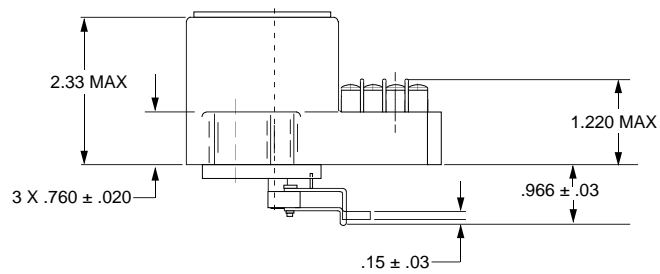
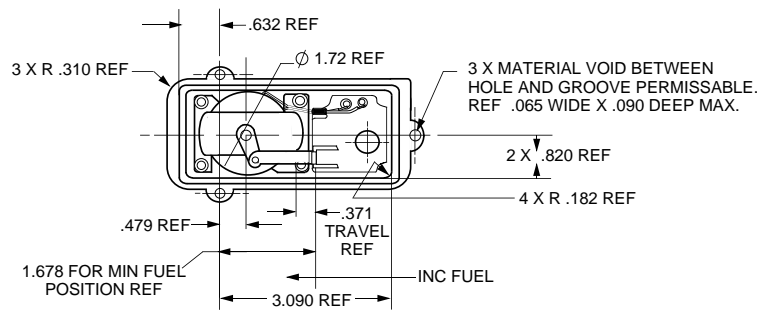
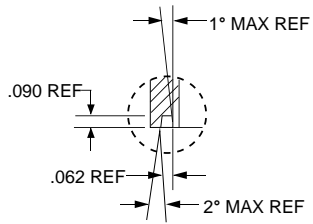
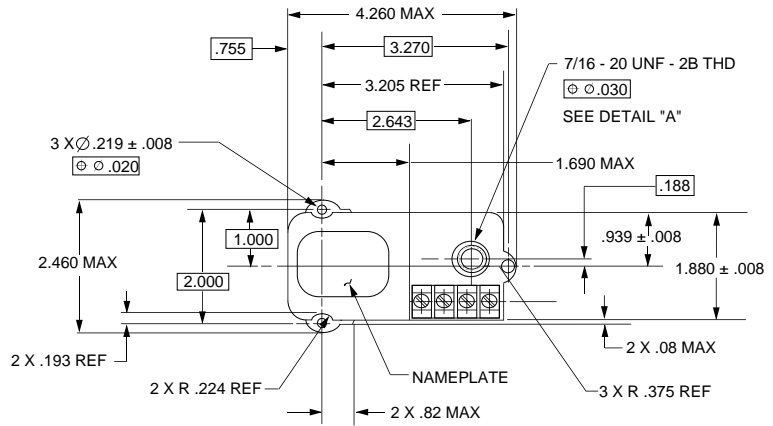
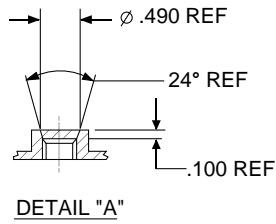

Installation Dimensions — DYNC-70025-001-0-12/24

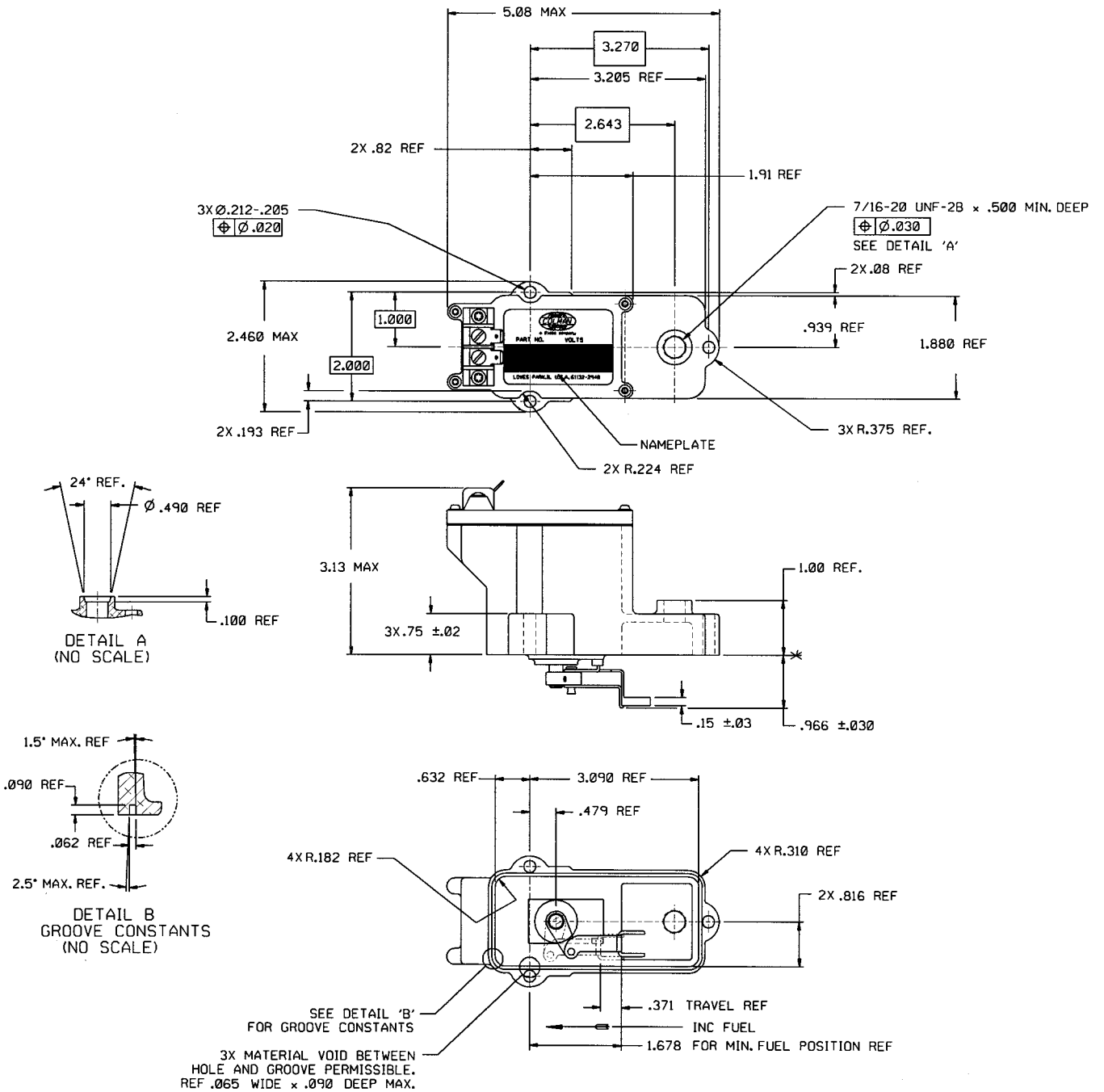

Specifications

Operating Characteristics		
Nominal Voltage	12 Volts DC	24 Volts DC
Current Amps Nominal	2.5 Amps	1.94 Amps
Current Max Stall	6 Amps	2.2 Amps
Stroke	As Shown	
Duty Cycle	Continuous	
Temperature Range	-55°C to 124°C -65°F to 250°F	
Direction Of Travel	Increasing current causes travel in the direction shown (INC FUEL)	
Finished Weight	1 lb. 12 oz. max	
Finished Mass	.79 kg max	

Typical Applications

- 1 Generator Sets
- 1 Forklift Trucks
- 1 Ground Power Carts
- 1 Agriculture Vehicles
- 1 Off-Road Vehicles
- 1 Pump Sets
- 1 Pleasure Boats
- 1 Wood Chippers

Available Controllers

- DYN1-10784-000-0-12/24
- DYN1-10786-000-0-12/24
- DYN1-10794-000-0-12/24

- DYN1-10784-001-0-12/24
- DYN1-10786-001-0-12/24
- DYN1-10794-002-0-12/24



Input Signal Frequency

- 2500 - 5000 Hz
- 5000 - 9500 Hz
- 2500 - 5000 Hz
- 2500 - 5000 Hz
- 5000 - 9500 Hz
- 2500 - 5000 Hz

Stanadyne Pump Models

- 1 DB
- 1 JDB
- 1 DC
- 1 DB2
- 1 DB4
- 1 DM2
- 1 DM4



7301 W. Wilson Ave
Harwood Heights, IL 60706

Telephone (780) 887-5400
Email sales@qccorp.com

NOTE

QCC believes that all information provided herein is correct and reliable and reserves the right to update at any time. QCC does not assume any responsibility for its use unless otherwise expressly undertaken.

CAUTION

As a safety measure, the engine should be equipped with an independent overspeed shutdown device in the event of failure which may render the governor inoperative.