

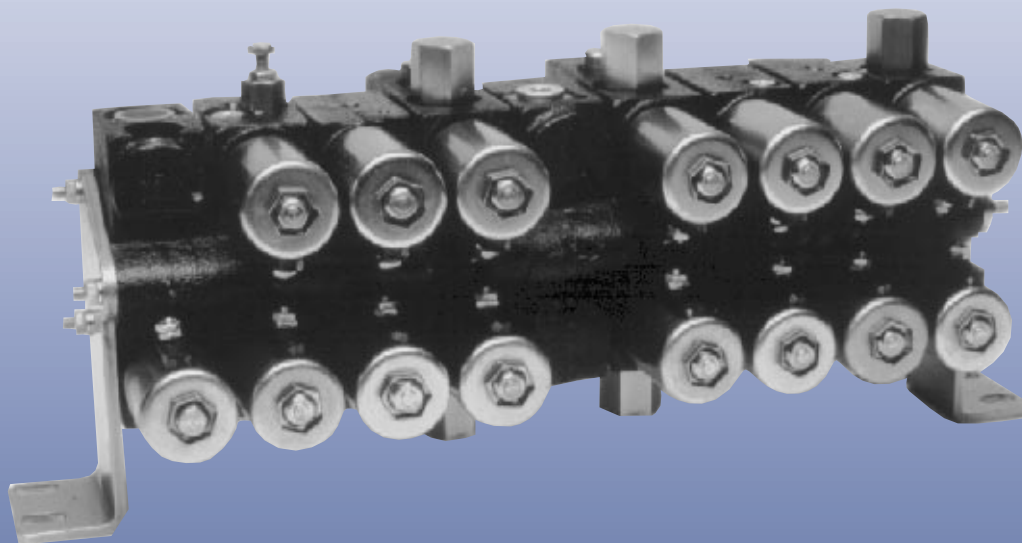

ZMC and ZMV



Electrohydraulic Valves

Technical Information



General Description

ZMC stack valves and ZMV proportional valves can be applied with pumps and various actuators to transfer and control hydraulic power.

ZMC valves are solenoid-operated stack valves used to control the direction of hydraulic fluid flow to motors, cylinders, and other remote actuators.

ZMC valves use a unique through-tube design to transfer fluid from module to module in the stack. The solenoid pilot valves are a reliable three piece design. Solenoids are water resistant with several terminations and voltages available.

The solenoid-operated pilot valves supply pilot flow to the larger directional control spools and poppets. This allows for full pressure to shift these spools when the pilot valve is energized.

ZMV valves are solenoid-operated proportional flow controls used to control the amount of flow to a hydraulic actuator.

The ZMV proportional valves are stand-alone designs that are controlled by a pulse width modulated (PWM) signal. Electronic controllers are also available to satisfy system requirements.

ZMV and ZMC valves - Solutions for Low Flow Applications

Complete Line of Directional Control Valves

Optional Spools to Satisfy Diverse Applications

Proven Reliability & Performance

Modular Product Design



ZMC and ZMV Electrohydraulic Valves

Technical Information

Contents

Introduction	2
General Description	2
Product Features	4
Technical Specifications	5
ZMC Module Specifications	6
ZMC - UVO Module: 2-Position/2-Way Normally Open Unload Valve	7
ZMC - UVC Module: 2-Position/2-Way Normally Closed Unload Valve	8
ZMC - UVF Module: 2-Position/2-Way Field Convertible Unload Valve	9
ZMC - URO Module: 2-Position/2-Way Normally Open Unload Valve with Integral Relief	10
ZMC - URF Module: 2-Position/2-Way Field Convertible Unload Valve with Integral Relief	11
ZMC - PRV Module: Pressure Reducing Valve	12
ZMC - PFD Module: Priority Flow Dividing Valve	13
ZMC - DPV Module: 3-Position/3-Way Demand Priority Valve	14
ZMC - SOV Module: 2-Position/2-Way Pilot-Operated Poppet Valve	15
ZMC - 240 Module: 2-Position/4-Way Criss-Cross Pilot-Operated Spool Valve	16
ZMC - 24C Module: 2-Position/4-Way Closed Center Pilot-Operated Spool Valve	17
ZMC - 340 Module: 3-Position/4-Way Figure Four Pilot-Operated Spool Valve	18
ZMC - 34C Module: 3-Position/4-Way Closed Center Pilot-Operated Spool Valve	19
ZMC - 34X Module: 3-Position/4-Way Figure Four Pilot-Operated Spool Valve with P-O Checks	20
ZMC - 34Y Module: 3-Position/4-Way Closed Center Pilot-Operated Spool Valve with P-O Checks	21
ZMC - PPV Module: 3-Position/3-Way Normally Closed Pilot-Operated Poppet Valve	22
ZMC - LFS Module: Standard Low Flow Valve	23
ZMC - LFH Module: High Pressure Low Flow Valve	24
ZMV Module Specifications	25
ZMV-21O: Open Center Proportional Flow Control Valve	26
ZMV-21P: Open Center Proportional Flow Control Valve with Power Beyond	27
ZMV-21C: Closed Center Proportional Flow Control Valve	28
ZMV-21L: Closed Center Load-Sensing Proportional Flow Control Valve	29
Configuration Options	30
Solenoids	30
Control Device Options	33
SCA-35: Single Channel Amplifier	33
Electronic Control Handle: MCH41CL2287	34
Orifice Plugs / Plates	35
Required Assembly Hardware	36
Through Tubes / Plug Tubes	36
Stacking Configurations	37
Stacking Kits	38
Module Identification	41
Outline Drawings	42



Product Features

A Complete Family

Wide Range of Options

System Flexibility -
Normally Open, Normally Closed, and Field
Convertible Valve Assemblies

Standard Housing and Mounting Patterns for
Stacking Any Module

Pressure Controls for System Protection

Pilot-Operated Checks for Load Holding

Performance

Pressure to 210 bar (3000 psi)

Flows to 38 l/min (10 gpm)

Fast Response Times

Low Leakage Spools

Low Pressure Drop

Pilot Operation

World Product

Sold Worldwide

Mobile and Stationary Markets

Proven Technology

Unique Product Features

Unique Assembly and Testing Methods
Increases Reliability

Stack Design Lowers Installation Cost

Electrohydraulic Proportional Valves For
Infinitely Variable Flow

Custom Module Designs for Unique
Applications

Reliability / Durability

Long Service Life

Continuous Duty Solenoids



Technical Specifications

Design

Stackable and stand alone two-stage, pilot-operated valves in gray iron housings with hardened steel spools.

Mounting Configuration

Foot or plate mountings available for horizontal or vertical configuration

Installation Position

The valves may be mounted in any orientation.

Electrical Connections

Several terminations and voltages to choose from (see page 32).

Port Connections

All ports are standard SAE O-ring boss ports. See Order Code (p. 6) or Outline Drawings (p. 45) for specific port sizes.

Stack Size

One to eight valve modules per stack.

Corrosion Resistance

Iron housing are painted black. Other external parts are zinc plated.

Technical Data:

	ZMC Stack Valves	ZMV Proportional Valves
Maximum Pressure Rating	210 bar 3000 psi	210 bar 3000 psi
Flow Rating	38 l/min 10 gpm	38 l/min 10 gpm
Minimum Working Pressure	20 bar 300 psi	Not Applicable
Response Time	0.010 to 0.75 sec	Not Applicable
Weight per Module	2.6 to 4.2 kg 5.7 to 9.2 lb	4.2 kg 9.2 lb
Spool Leakage (at 210 bar [3000 psi])	164 cm ³ /min 10 in ³ /min	2.0 cm ³ /min 0.5 in ³ /min
Poppet Leakage	2 drops/min	Not Applicable
Electrical Current Range for Continuous Duty Coils	0.83 to 1.5 Amp (±20% Voltage Tolerance)	0 to 1.0 Amp (±20% Voltage Tolerance)
Temperature Range: Buna-N Seals Viton Seals	-35°/120°C [-30°/250°F] -25°/205°C [-15°/400°F]	-35°/120°C [-30°/250°F] -25°/205°C [-15°/400°F]
Hydraulic Fluid	Any general hydraulic fluid	Any general hydraulic fluid
Filtration	10 micron nominal	10 micron nominal

The ZMC series offers flexibility for designing an electrohydraulic system to meet your exact requirements. It is comprised of a family of solenoid-operated valve modules, each designed for the optimum control of a particular function. All ZMC modules share a common mounting and porting pattern. This allows a ZMC valve stack using any combination of modules to be assembled for an exact application. With ZMC modules, a single hydraulic power source (i.e. pump) can supply multiple actuating requirements.



Normally open and normally closed configurations are available for most valves. Field convertible configurations are available for the unload valves. If the ZMC stack is in a normally open mode, a ZMC unload valve (ZMC-UVx or ZMC URx) is used as a system inlet and bypass module.

Typical ZMC Stack

This typical ZMC stack consists of several modules to operate a grain harvesting combine's auxiliary functions. Header control and unloading auger operation are examples of auxiliary functions controlled by the valve stack in the schematic below. Any combination of ZMC modules could be included to customize the valve stack for a particular application.

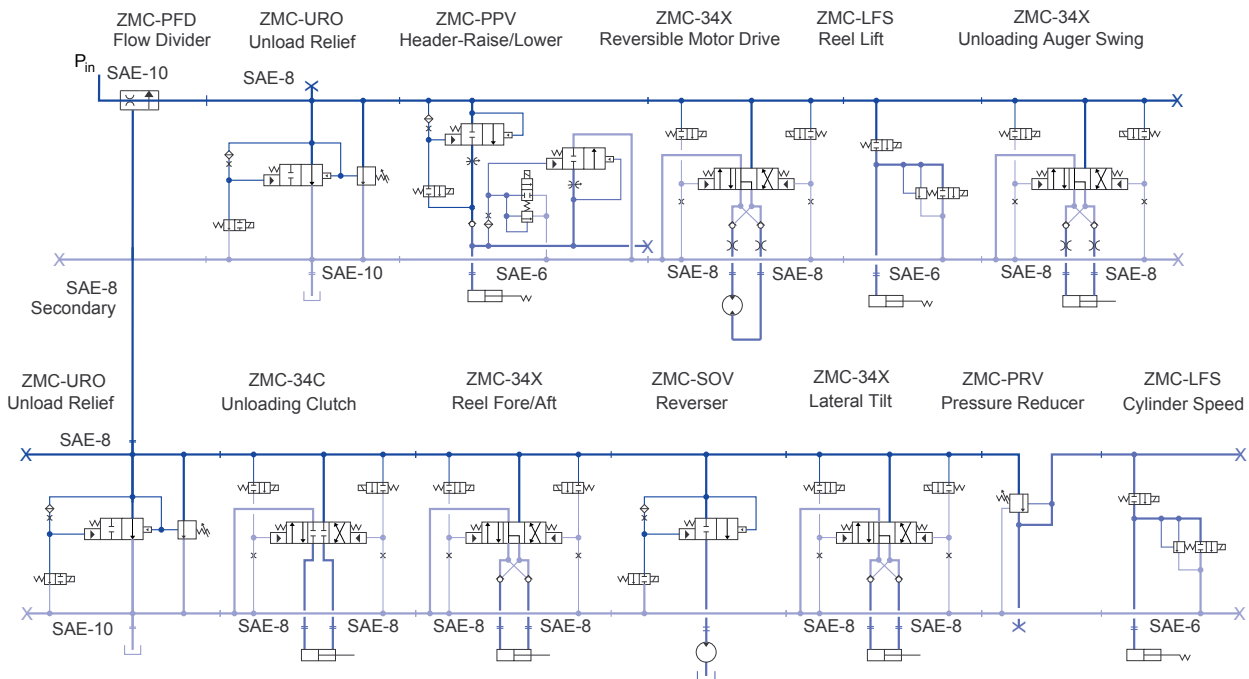



ZMC - UVO Module: 2-Position/2-Way Normally Open Unload Valve

Description

The UVO module is a two-position, two-way solenoid-operated poppet valve. This module allows a stack assembly to operate in an open center configuration. This reduces power consumption by unloading flow to tank when it is not required by the actuator.

The UVO module is normally open. It is designed for low pressure drop at high flows.

Operation

The valve will dump flow to tank when the solenoid is de-energized. When the valve is energized the pilot will block flow and build pressure in the spring chamber of the main poppet, forcing it closed. Then flow can be ported through the pressure gallery to another valve and the hydraulic function.

Specifications

Weight		2.6 kg	5.7 lb
Ports:	Pressure	#8 SAE 3/4-16	
	Tank	#10 SAE 7/8-14	
Response Time (sec)			
Coil Duty:		Continuous	
Closed to Open		0.060	
Open to Closed		0.015	

UVO Pressure Drop Curve

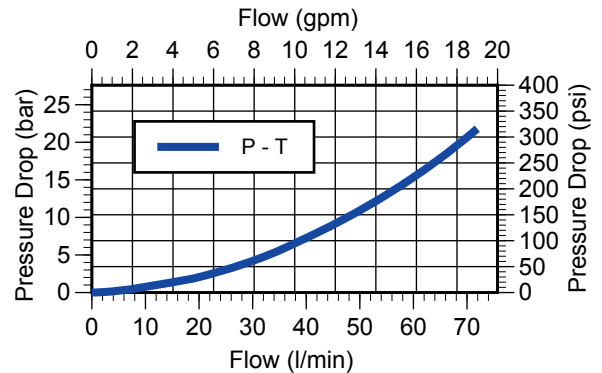

UVO Schematic

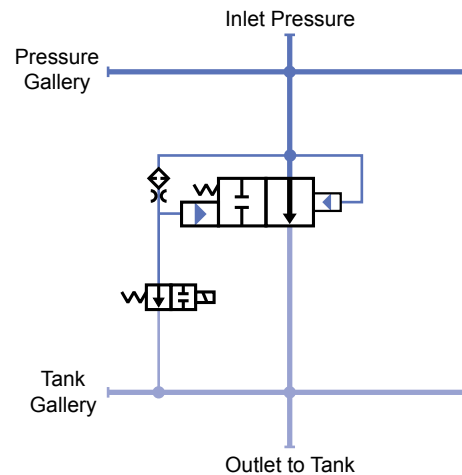

UVO Cut-away

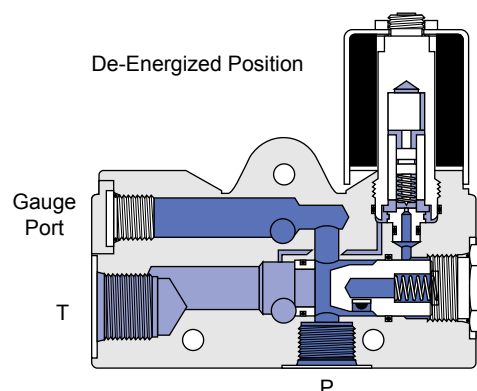

ZMC - UVC Module: 2-Position/2-Way Normally Closed Unload Valve

Description

The UVC module is a two-position, two-way solenoid-operated poppet valve. This module allows a stack assembly to operate in an closed center configuration.

The UVC module is normally closed. It is designed for low pressure drop at high flows.

Operation

The valve will dump flow to tank when the solenoid is energized. When the valve is de-energized the pilot will block flow and build pressure in the spring chamber of the main poppet, forcing it closed. Flow can then be ported through the pressure gallery to another valve and the hydraulic function.

Specifications

Weight		2.6 kg	5.7 lb
Ports:	Pressure	#8 SAE 3/4-16	
	Tank	#10 SAE 7/8-14	
Response Time (sec)			
Coil Duty:		Continuous	
Closed to Open		0.060	
Open to Closed		0.015	

UVC Pressure Drop Curve

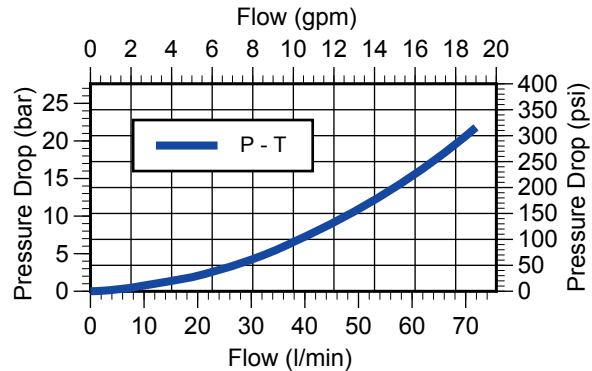

UVC Schematic

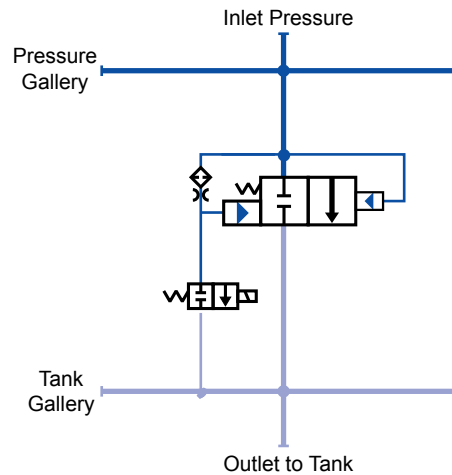

UVC Cut-away

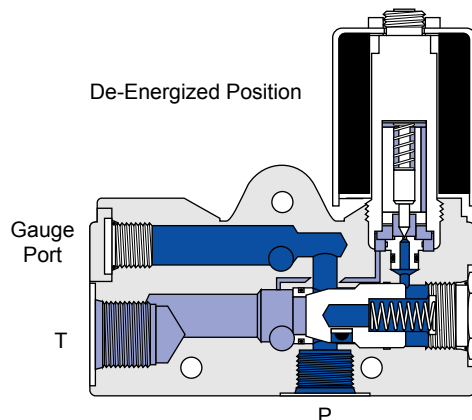



ZMC - UVF Module: 2-Position/2-Way Field Convertible Unload Valve

Description

The UVF module is a two-position, two-way solenoid-operated poppet valve. This module allows a stack assembly to operate in an open center or closed center configuration.

The UVF module's normal mode is field convertible. A field conversion adjustment screw allows it to be changed between a normally open and a normally closed configuration. The initial setting is open.

Operation

The valve will dump flow to tank when the solenoid is de-energized. When the valve is energized the pilot will block flow and build pressure in the spring chamber of the main poppet, forcing it closed. Then flow can be ported through the pressure gallery to another valve and the hydraulic function.

Specifications

Weight		2.6 kg	5.7 lb
Ports:	Pressure	#8 SAE 3/4-16	
	Tank	#10 SAE 7/8-14	
Response Time (sec)			
Coil Duty:		Continuous	
Closed to Open		0.060	
Open to Closed		0.015	

UVF Pressure Drop Curve

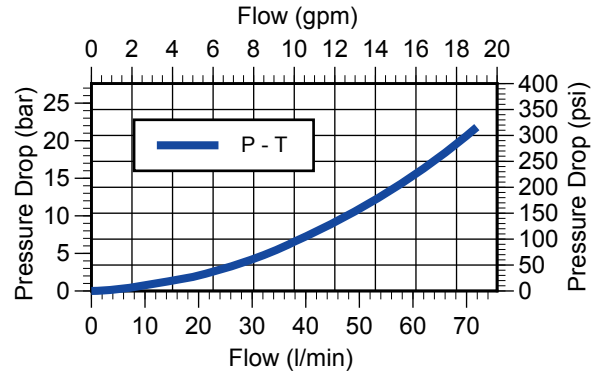

UVF Schematic

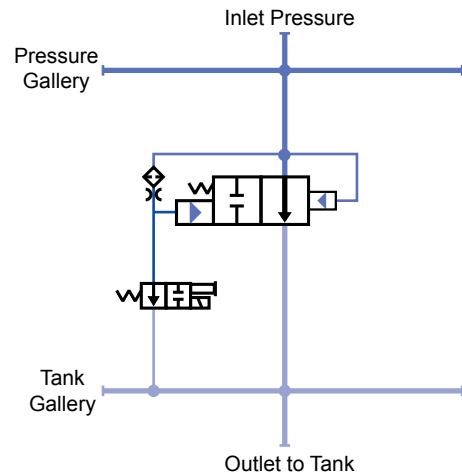

UVF Cut-away

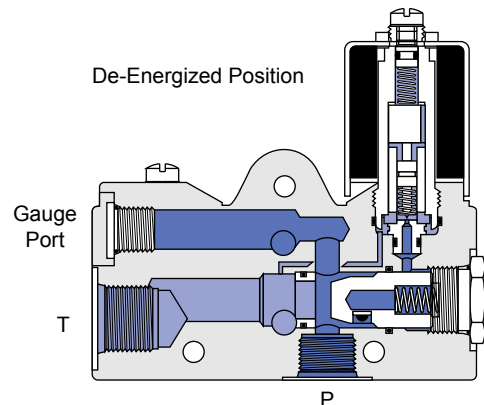

ZMC - URO Module: 2-Position/2-Way Normally Open Unload Valve with Integral Relief

Description

The URO module is a two-position, two-way solenoid-operated poppet valve with an integral cartridge-style relief valve. This module allows a stack assembly to operate in an open center configuration. This reduces power consumption by unloading flow to tank when it is not required by the actuator. It includes a relief valve for system pressure protection.

The URO module is normally open. It is designed for low pressure drop at high flows.

Operation

The module will dump flow to tank when the solenoid is de-energized. When the valve is energized the pilot will block flow and build pressure in the spring chamber of the main poppet, forcing it closed. Then flow can be ported onward to another valve and the mechanical application.

The pilot-operated relief valve is a full flow valve that will open at any time pressure is higher than the valve setting. The valve pressure setting is based on a 38 l/min (10 gpm) flow rate. It is set with an adjustable screw and available with a tamper-proof cap.

Specifications

Weight	2.6 kg	5.7 lb
Ports:	Pressure	#8 SAE 3/4–16
	Tank	#10 SAE 7/8–14
Response Time (sec)		
Coil Duty:	Intermittent	Continuous
Open to Closed	0.090	0.090
Closed to Open	0.020	0.030
Relief Valve Setting	20 - 200 bar	300 - 3000 psi

URO Pressure Drop Curve

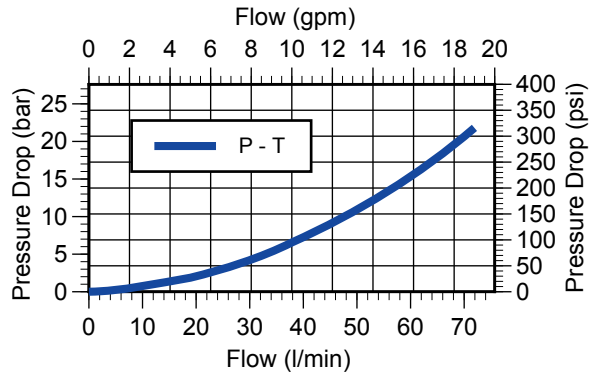

URO Schematic

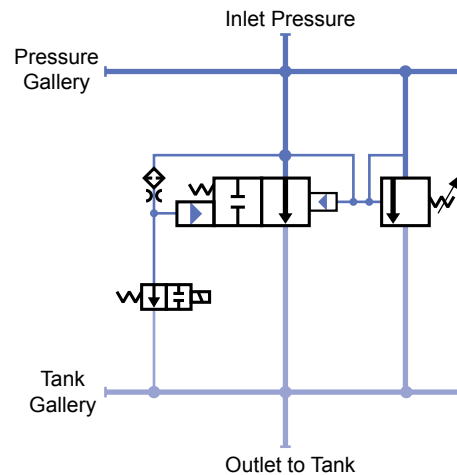

URO Cut-away

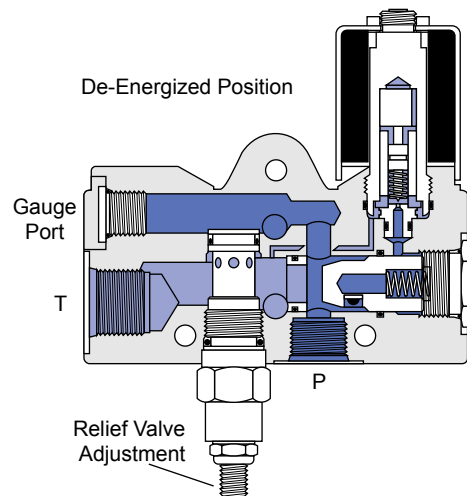



ZMC - URF Module: 2-Position/2-Way Field Convertible Unload Valve with Integral Relief

Description

The URO module is a two-position, two-way solenoid-operated poppet valve with an integral cartridge-style relief valve. This module allows a stack assembly to operate in an open center configuration. This reduces power consumption by unloading flow to tank when it is not required by the actuator. It includes a relief valve for system pressure protection.

The URF module's normal mode is field convertible. A field conversion adjustment screw allows it to be changed between a normally open and a normally closed configuration. The initial setting is open.

Operation

The module will dump flow to tank when the solenoid is de-energized. When the valve is energized the pilot will block flow and build pressure in the spring chamber of the main poppet, forcing it closed. Then flow can be ported onward to another valve and the mechanical application.

The pilot-operated relief valve is a full flow valve that will open at any time pressure is higher than the valve setting. The valve pressure setting is based on a 38 l/min (10 gpm) flow rate. It is set with an adjustable screw and available with a tamper-proof cap.

Specifications

Weight	2.6 kg	5.7 lb
Ports:	Pressure	#8 SAE 3/4-16
	Tank	#10 SAE 7/8-14
Response Time (sec)		
Coil Duty:	Intermittent	Continuous
Open to Closed	0.090	0.090
Closed to Open	0.020	0.030
Relief Valve Setting	20 - 200 bar	300 - 3000 psi

URF Pressure Drop Curve

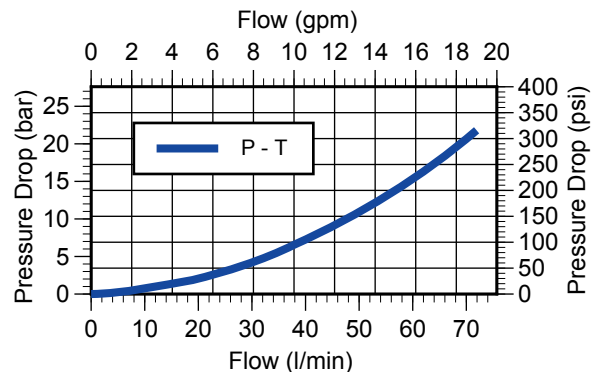

URF Schematic

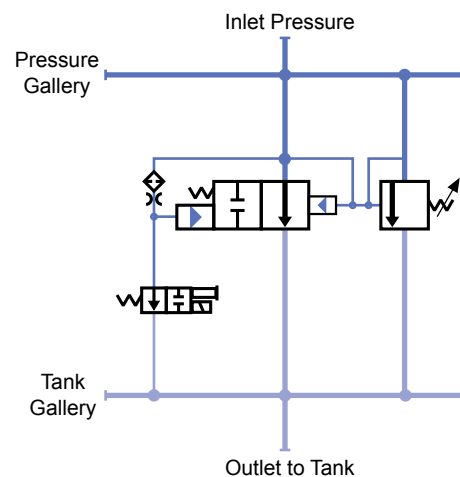

URF Cut-away

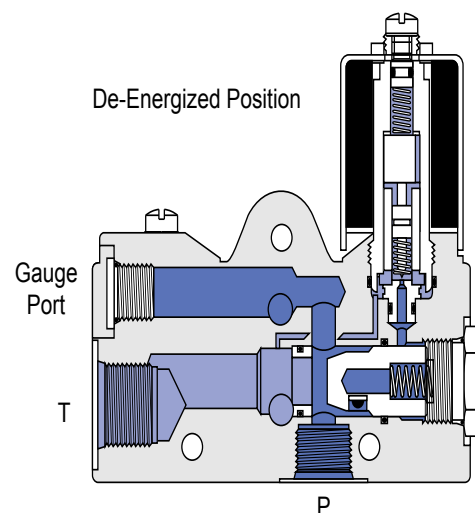

ZMC - PRV Module: Pressure Reducing Valve

Description

The PRV module contains a cartridge-style, pilot-operated pressure-reducing and -relieving valve. This valve provides a reduced pressure in all modules in the stack downstream of the PRV. This pressure is maintained regardless of flow.

Operation

The valve is normally open to flow downstream. When the pressure setting of the valve is reached the valve will close to stop flow while maintaining the reduced pressure downstream. If downstream pressure rises above this setting, the valve will open and relieve that pressure to tank.

Specifications

Weight	2.3 kg	5.0 lb
Leakage	11.5 cm ³ /min	0.7 in ³ /min
Pressure Setting Range	35 - 200 bar	500 - 3000 psi

PRV Pressure Drop Curve

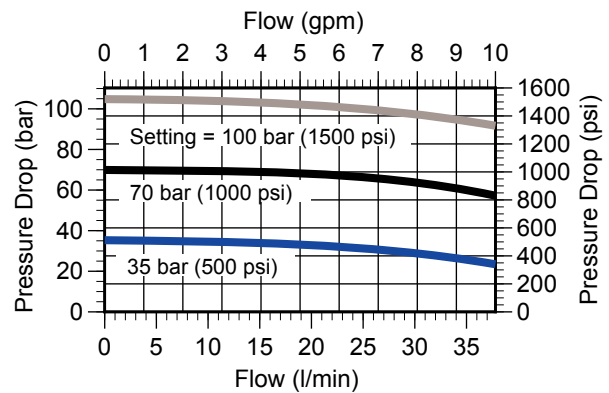

PRV Schematic

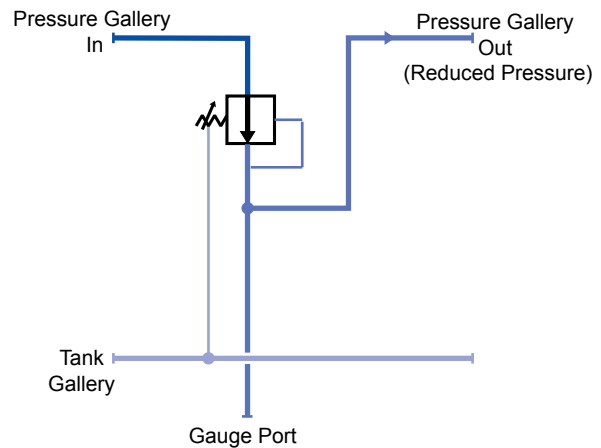

PRV Cut-away

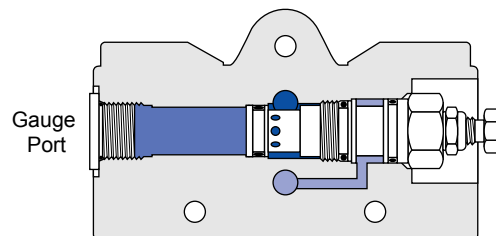

ZMC - PFD Module: Priority Flow Dividing Valve

Description

The PFD module is used to split flow into two parts (e.g. for two sections of stack). The priority flow is constant and sent through the priority pressure gallery. This flow is pressure compensated to maintain constant priority flow regardless of load pressure. Excess flow is ported through the secondary pressure gallery for use in another set of valves or it can be sent through an optional external port.

Operation

Inlet flow passes through the orifice at the end of the spool and passes through the spool center and out to the priority pressure gallery. The pressure drop across this orifice causes the spool to shift right against the spring. The spool then meters excess flow to the secondary port.

Specifications

Weight		2.5 kg	5.5 lb
Ports:	Pressure	#10 SAE 7/8–14	
	Secondary*	#8 SAE 3/4–16	
Compensating Pressure		15 bar	250 psi

* optional

PFD Pressure Drop Curve

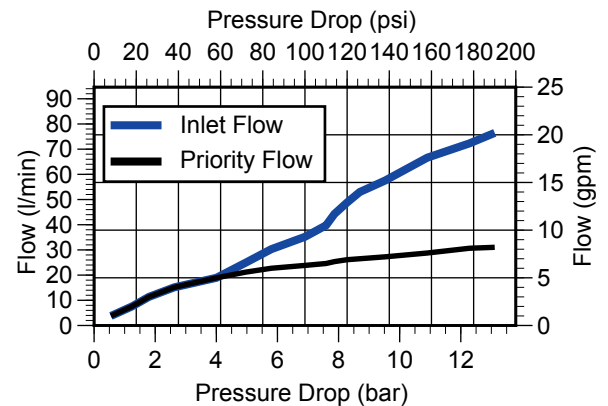

PFD Schematic

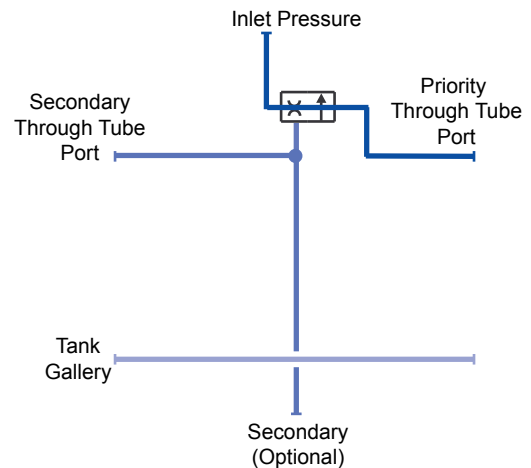

PFD Cut-away

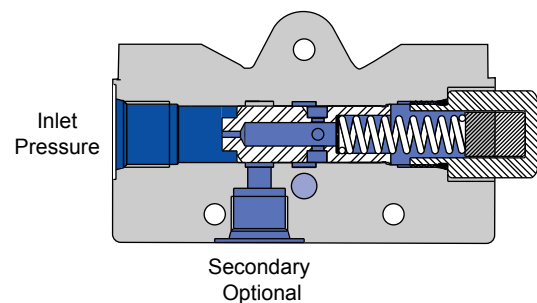

ZMC - DPV Module: 3-Position/3-Way Demand Priority Valve

Description

The DPV module is a priority flow control valve. It is used to supply priority flow to a steering valve. Excess flow is bypassed to the module pressure gallery. This module also contains a dynamic load sense port which can be connected to a steering motor load sense port. This allows the motor to demand flow from the valve when it is required.

Operation

When no flow is required by the steering motor, the load sense line is connected to the tank through the motor and the priority flow is blocked. Priority port pressure causes the spool to shift, diverting flow to the valve module's pressure gallery. When steering flow is required, a variable orifice in the external steering motor's load sense line narrows sending a pressure signal to the spring end of the spool. This causes the spool to shift diverting a portion of the flow to the priority port. The amount of priority port flow is controlled by the load sense line pressure. Priority port pressure is limited by an externally adjustable relief cartridge connected to the load sense line.

Specifications

Weight		3.9 kg	8.5 lb
Ports:	Pressure	#10 SAE 7/8-14	
	Priority	37° Flare JIC #8	
	Load Sense	#4 SAE 7/16-20	
Priority Pressure		200 bar	3000 psi
Rated Flow	Pressure	64 l/min	17 gpm
	Priority	19 l/min	5 gpm

Load Sense Pressure vs. Priority Flow

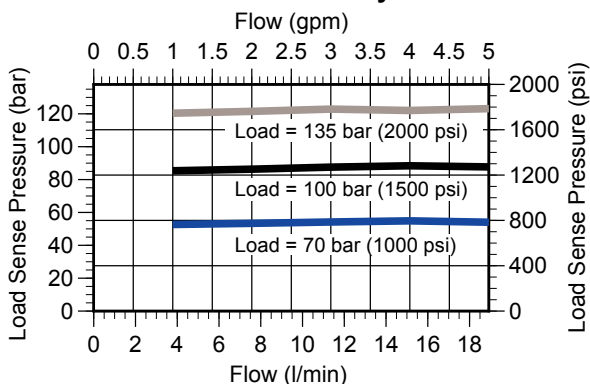

DPV Pressure Drop Curve

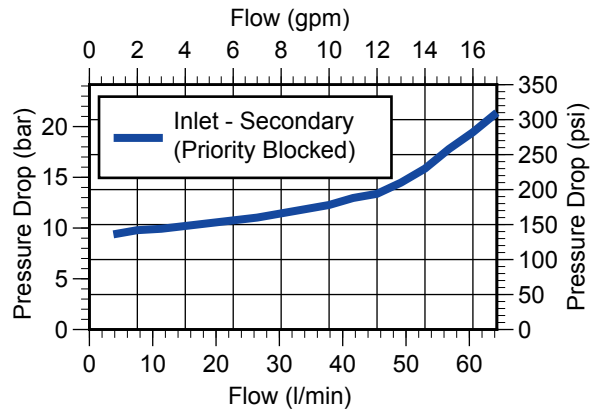

DPV Schematic

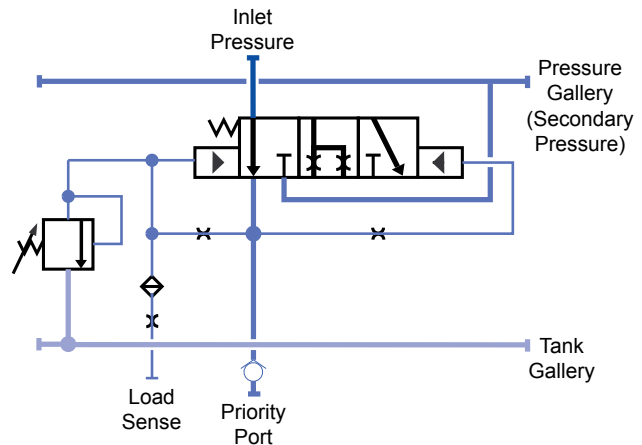

DPV Cut-away

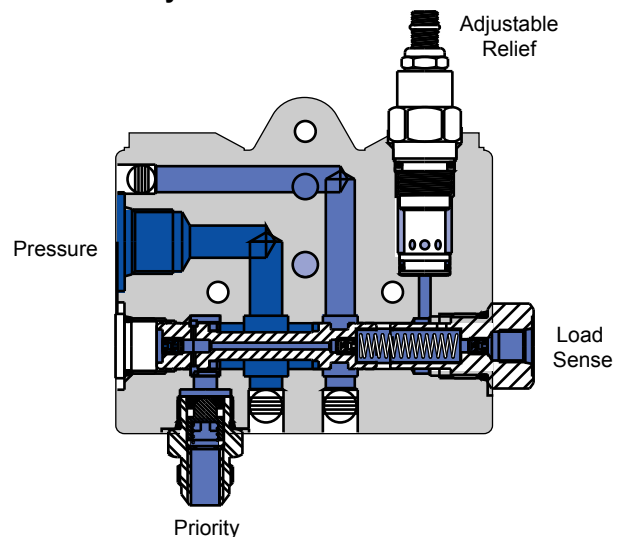

ZMC - SOV Module: 2-Position/2-Way Pilot-Operated Poppet Valve

Description

The SOV module is a normally closed two-position, two-way solenoid-operated poppet valve. It is commonly used to control flow to a motor or other unidirectional actuators.

It is designed for low pressure drop and minimal leakage.

Operation

The valve is spring-biased closed. Energizing the solenoid will allow the pilot valve to open which drains the poppet spring chamber. Inlet flow overcomes the spring and opens the poppet. Flow is then channeled through the work port.

Specifications

Weight	2.6 kg	5.7 lb
Ports:	Work	#10 SAE 7/8-14
Response Time (sec)		
Coil Duty:	Intermittent	Continuous
Open to Closed	0.010	0.015
Closed to Open	0.070	0.060

SOV Pressure Drop Curve

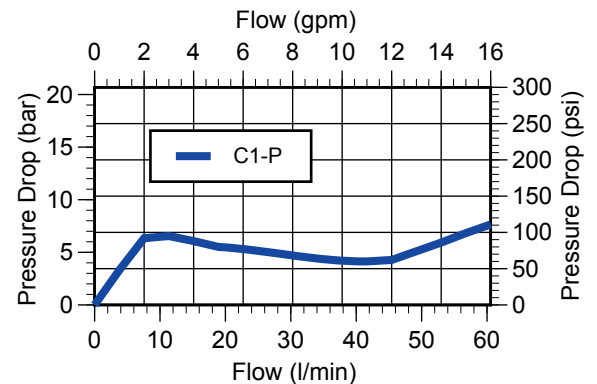

SOV Schematic

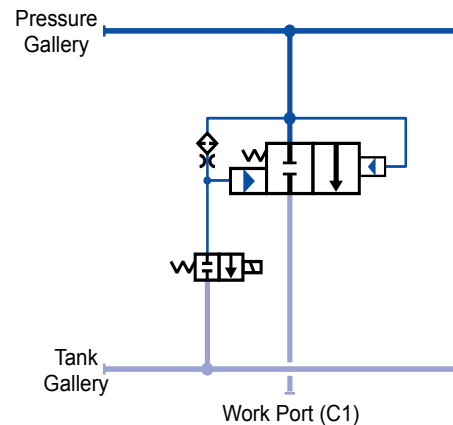

SOV Cut-away

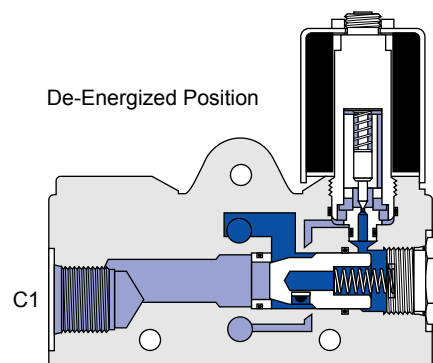



ZMC - 240 Module: 2-Position/4-Way Criss-Cross Pilot-Operated Spool Valve

Description

The 240 module is a two-position, four-way spool valve. It is commonly used as directional control for dual-acting clutch cylinders.

This module is designed to accept orifice plugs or unidirectional orifice plates in the work ports. Please see page 37 for information on selecting orifice size.

Operation

The spool is spring-biased to one flow path. Energizing the solenoid will allow the pilot valve to open which supplies inlet pressure to the other end of the spool. This pressure will overcome the spring and shift the spool.

Specifications

Weight	2.7 kg	6.0 lb
Ports: Work	#8 SAE 3/4-16	
Response Time (sec)		
Coil Duty:	Intermittent	Continuous
Open to Closed	0.050	0.070
Closed to Open	0.150	0.115

240 Pressure Drop Curve

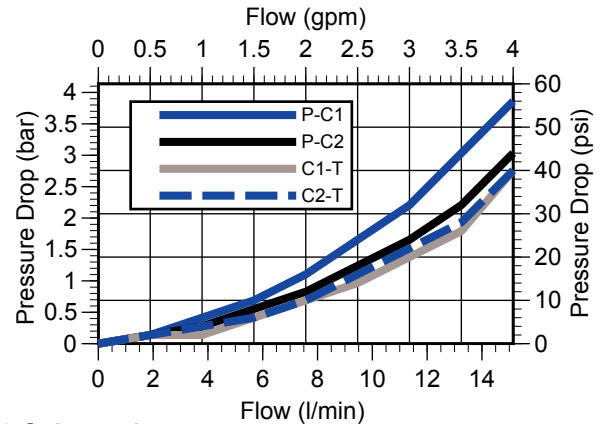

240 Schematic

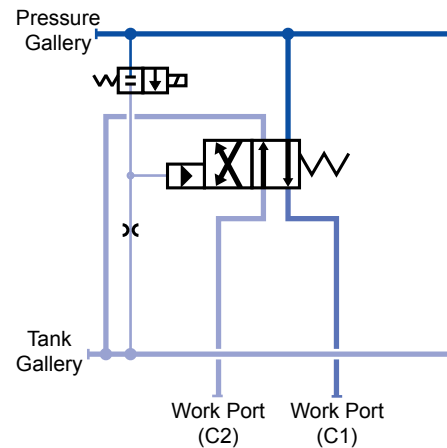

240 Cut-away

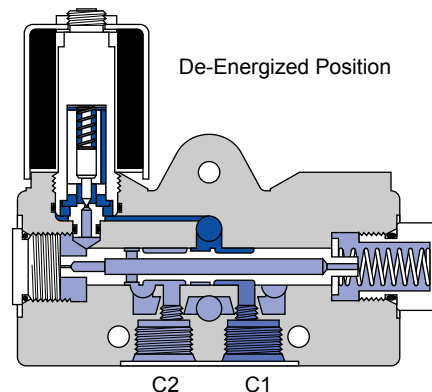

ZMC - 24C Module: 2-Position/4-Way Closed Center Pilot-Operated Spool Valve

Description

The 24C module is a two-position, four-way spool valve. The valve is closed in de-energized mode. It is commonly used for dual-acting, spring-returned cylinders, or unidirectional motors.

This module is designed to accept orifice plugs or unidirectional orifice plates in the work ports. Please see page 37 for information on selecting orifice size.

Operation

The spool is spring-biased to a center-blocked position. Energizing the solenoid will allow the pilot valve to open which supplies inlet pressure to one end of the spool. This pressure will overcome the spring and shift the spool.

Specifications

Weight	2.7 kg	6.0 lb
Ports:	Work	#8 SAE 3/4-16
Response Time (sec)		
Coil Duty:	Intermittent	Continuous
Open to Closed	0.050	0.070
Closed to Open	0.150	0.115

24C Pressure Drop Curve

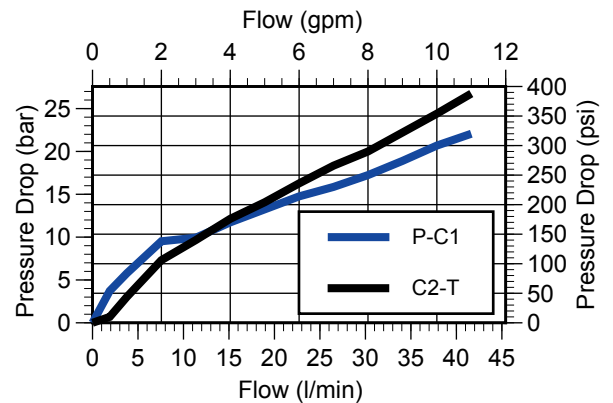

24C Schematic

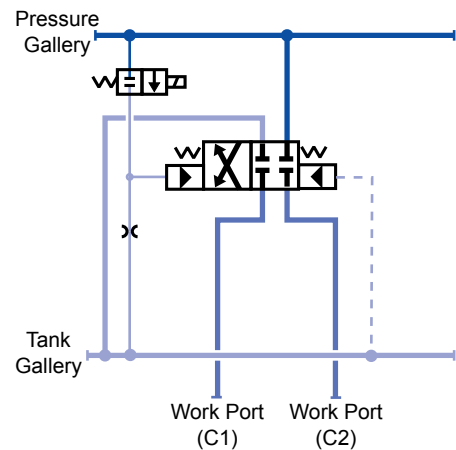

24C Cut-away

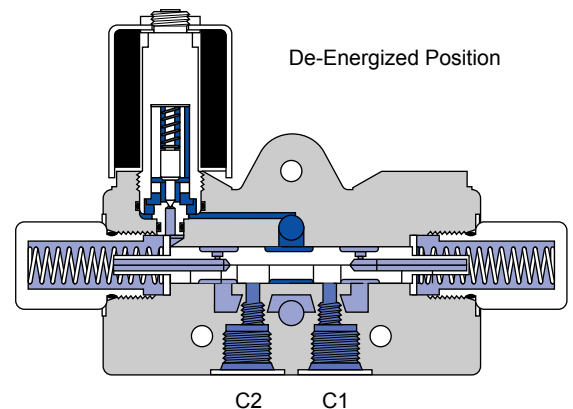



ZMC - 340 Module: 3-Position/4-Way Figure Four Pilot-Operated Spool Valve

Description

The 340 module is a three-position, four-way solenoid-operated spool valve. It is commonly used as directional control for dual-acting cylinders or bidirectional motors.

This module is designed to accept orifice plugs or unidirectional orifice plates in the work ports. Please see page 37 for information on selecting orifice size.

Operation

The spool is spring-biased to the center position. Energizing either solenoid will allow the pilot valve to open which supplies inlet pressure to one end of the spool. This pressure will overcome the centering spring and shift the spool. The dual-solenoid design allows flow to be channeled in either direction.

Specifications

Weight	2.8 kg	6.1 lb
Ports: Work	#8 SAE 3/4-16	
Response Time (sec)		
Coil Duty:	Intermittent	Continuous
Open to Closed	0.065	0.100
Closed to Open	0.085	0.085

340 Pressure Drop Curve

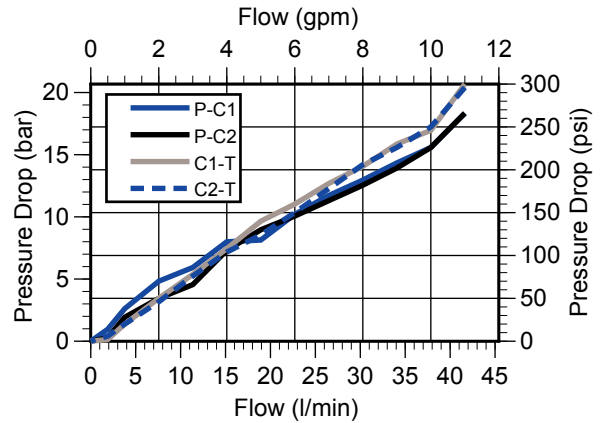

340 Schematic

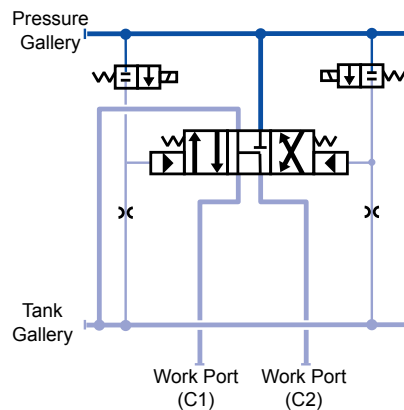

340 Cut-away

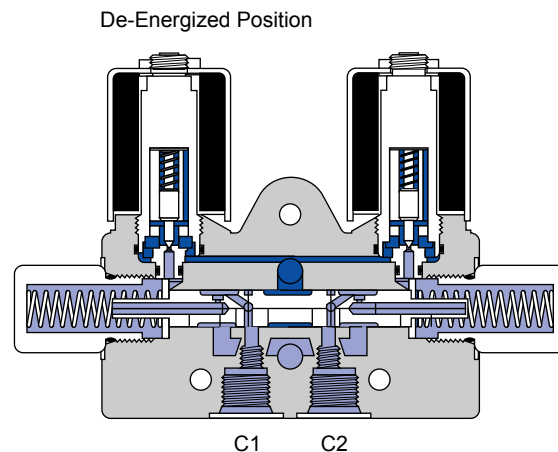

ZMC - 34C Module: 3-Position/4-Way Closed Center Pilot-Operated Spool Valve

Description

The 34C module is a three-position, four-way solenoid-operated spool valve. It is commonly used as directional control for dual-acting cylinders or bidirectional motors.

This module is designed to accept orifice plugs or unidirectional orifice plates in the work ports. Please see page 37 for information on selecting orifice size.

Operation

The spool is spring-biased to the center-blocked mode. Energizing either solenoid will allow the pilot valve to open which supplies inlet pressure to one end of the spool. This pressure will overcome the centering spring and shift the spool. The dual-solenoid design allows flow to be channeled in either direction.

Specifications

Weight	2.8 kg	6.1 lb
Ports:	Work	#8 SAE 3/4-16
Response Time (sec)		
Coil Duty:	Intermittent	Continuous
Open to Closed	0.065	0.100
Closed to Open	0.085	0.085

34C Pressure Drop Curve

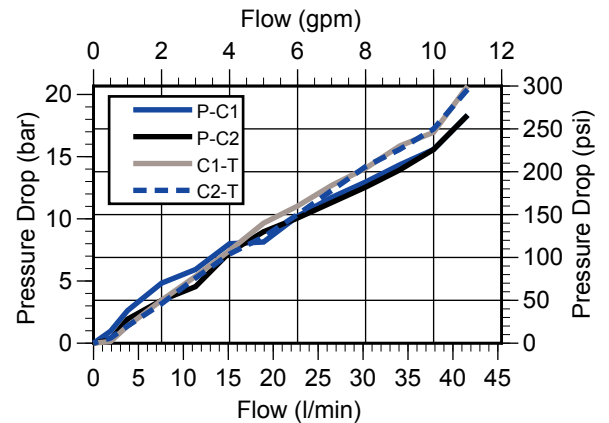

34C Schematic

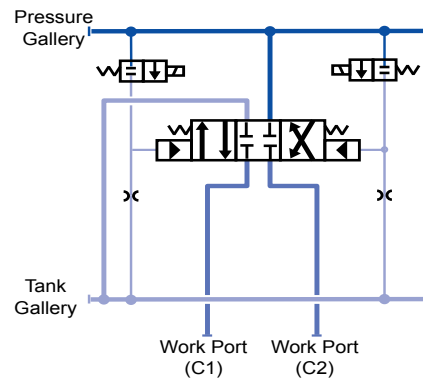

34C Cut-away

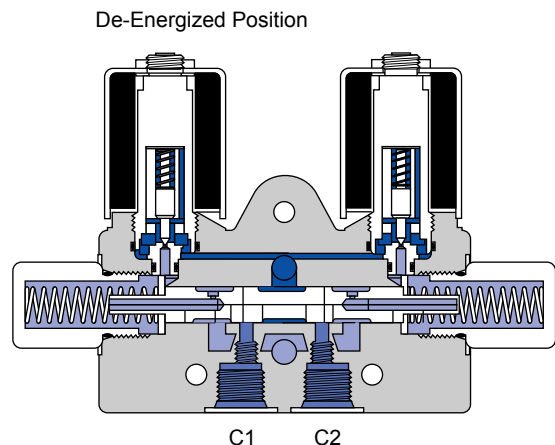



ZMC - 34X Module: 3-Position/4-Way Figure Four Pilot-Operated Spool Valve with P-O Checks

Description

The 34X module is a four-way, three-position solenoid-operated spool valve with single or dual pilot-operated checks for load holding. It is commonly used as directional control for dual-acting cylinders or bidirectional motors.

This module is designed to accept orifice plugs or unidirectional orifice plates in the work ports. Please see page 37 for information on selecting orifice size.

Operation

The spool is spring-biased to the center position. Energizing either solenoid will allow the pilot valve to open which supplies inlet pressure to one end of the spool. This pressure will overcome the centering spring and shift the spool. The dual-solenoid design allows flow to be channeled in either direction.

The pilot-operated checks are poppet style valves designed for low leakage. The checks will open when pilot pressure is 1/5 of the load pressure plus the spring crack pressure. Standard crack pressure is 7 bar (100 psi).

Specifications

Weight	4.2 kg	9.2 lb
Ports: Work	#8 SAE 3/4-16	
Response Time (sec)		
Coil Duty:	Intermittent	Continuous
Open to Closed	0.070	0.100
Closed to Open	0.095	0.090
Pilot Ratio	5:1	
Crack Pressure	7 bar	100 psi

34X Pressure Drop Curve

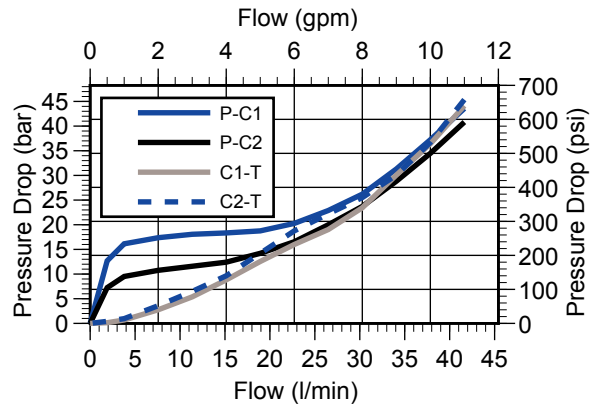

34X Schematic

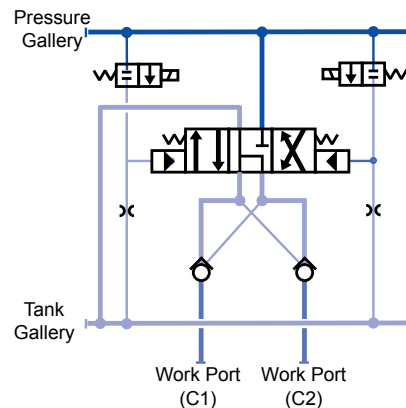

34X Cut-away

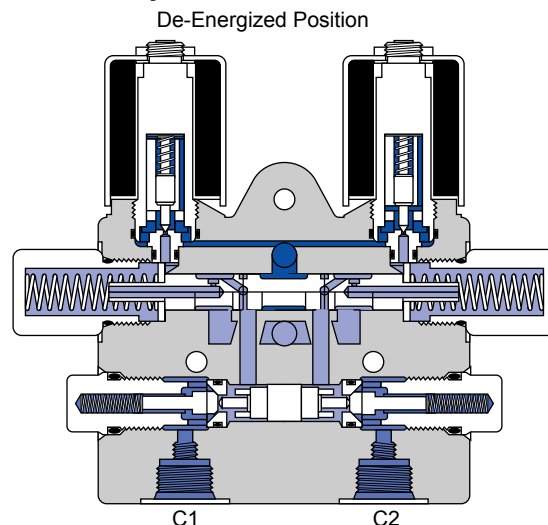

ZMC - 34Y Module: 3-Position/4-Way Closed Center Pilot-Operated Spool Valve with P-O Checks

Description

The 34Y module is a four-way, three-position solenoid-operated spool valve with single or dual pilot-operated checks for load holding. It is commonly used as directional control for dual-acting cylinders or bidirectional motors.

This module is designed to accept orifice plugs or unidirectional orifice plates in the work ports. Please see page 37 for information on selecting orifice size.

Operation

The spool is spring-biased to the center-blocked position. Energizing either solenoid will allow the pilot valve to open which supplies inlet pressure to one end of the spool. This pressure will overcome the centering spring and shift the spool. The dual-solenoid design allows flow to be channeled in either direction.

The pilot-operated checks are poppet style valves designed for low leakage. The checks will open when pilot pressure is 1/5 of the load pressure plus the spring crack pressure. Standard crack pressure is 7 bar (100 psi).

Specifications

Weight	4.2 kg	9.2 lb
Ports:	Work	#8 SAE 3/4-16
Response Time (sec)		
Coil Duty:	Intermittent	Continuous
Open to Closed	0.070	0.100
Closed to Open	0.095	0.090
Pilot Ratio	5:1	
Crack Pressure	7 bar	100 psi

34Y Pressure Drop Curve

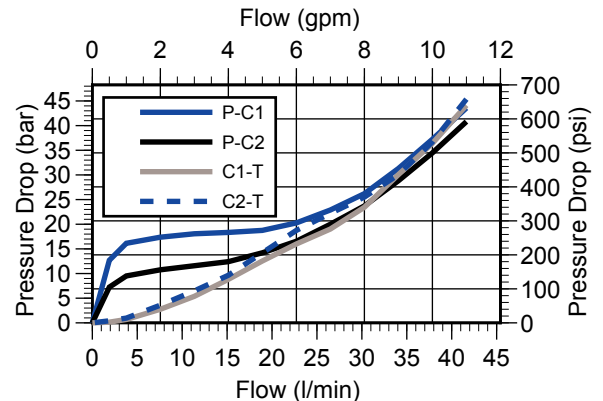

34Y Schematic

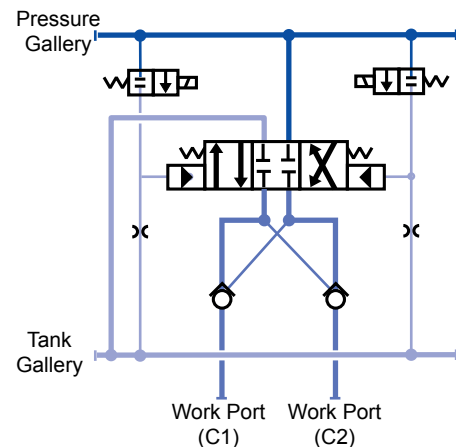

34Y Cut-away

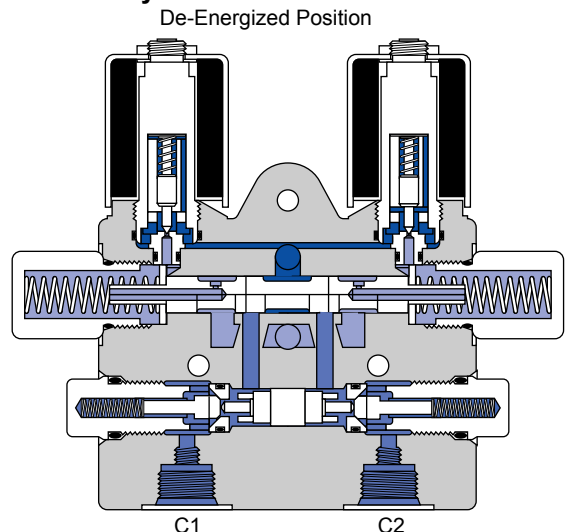



ZMC - PPV Module: 3-Position/3-Way Normally Closed Pilot-Operated Poppet Valve

Description

The PPV module is a three-position, three-way poppet valve. It is commonly used as directional control for single-acting cylinders.

This module also contains built in pressure protection for the work port, poppet type checks on the outlet, and two manually adjustable flow controls for the raise and lower functions.

The PPV module is designed with poppets to offer minimal leakage (2 drops/min) and low pressure drop.

Operation

The poppets are spring-biased closed. Energizing either solenoid will open the pilot valve which will vent the main poppet spring chamber. Pressure will overcome the spring and shift the poppet open. Energizing the Raise poppet will pressurize the work port. Energizing the Lower poppet will depressurize the work port.

Specifications

Weight	2.8 kg	6.1 lb
Ports:	Work	#6 SAE 9/16-18
Response Time (sec)		
Coil Duty:	Intermittent	Continuous
Open to Closed	0.050	0.145
Closed to Open	0.090	0.070

PPV Pressure Drop Curve

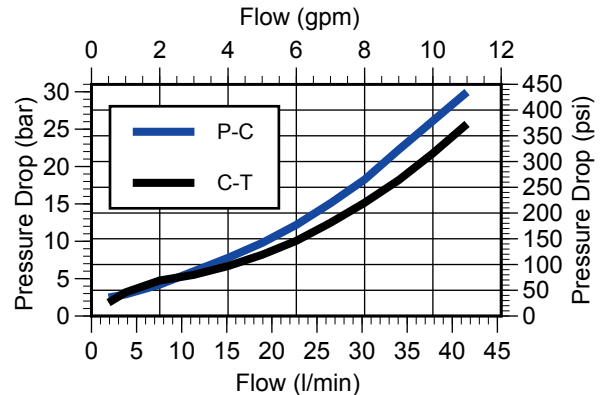

PPV Schematic

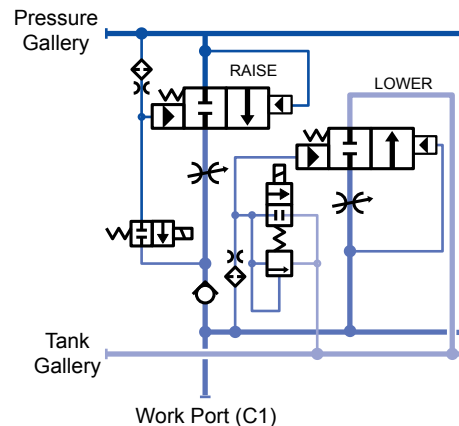

PPV Cut-away

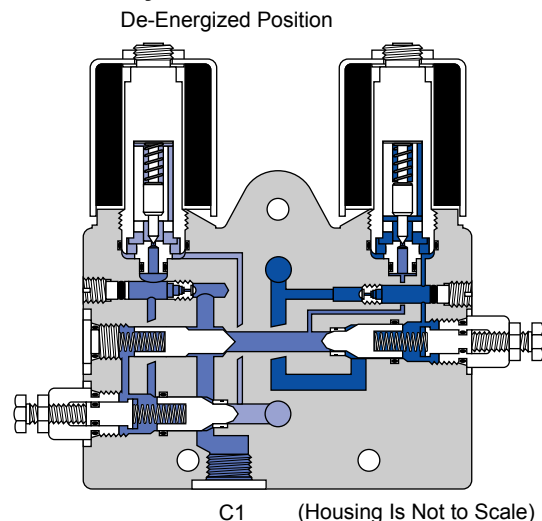

ZMC - LFS Module: Standard Low Flow Valve

Description

The LFS module is a three-way, three-position solenoid-operated poppet valve. It is commonly used as directional control for single-acting cylinders with low flow requirements. This module also contains pressure protection for the work port.

Operation

The direct-acting poppets are spring-biased closed. Energizing the solenoid will open the poppets and allow flow to or from the work port.

Specifications

Weight	3.1 kg	6.9 lb
Ports:	Work	#4 SAE 7/16-20
Response Time (sec)		
Coil Duty:	Intermittent	Continuous
Raise	.015	.03
Lower	.415	.57

LFS Cracking Pressure Curve

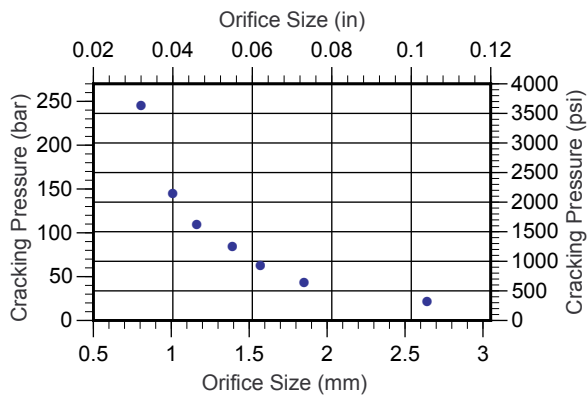

LFS Pressure Drop Curve

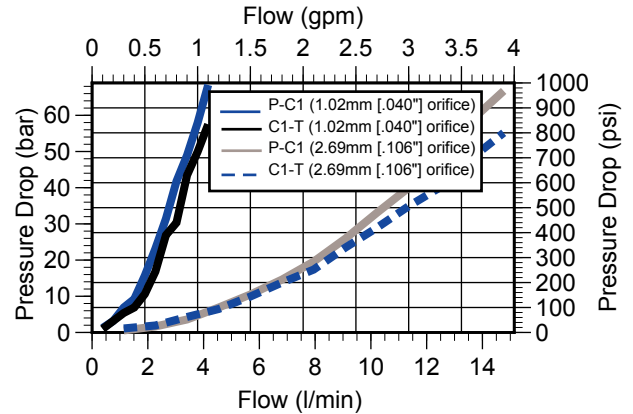

LFS Schematic

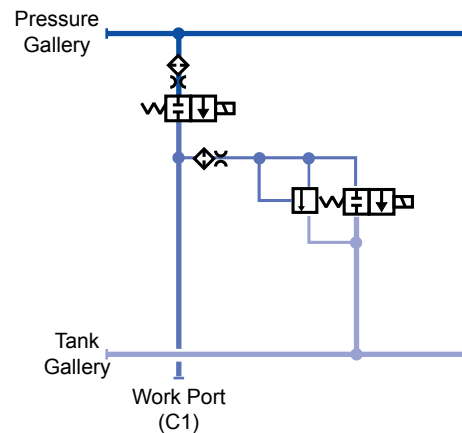

LFS Cut-away

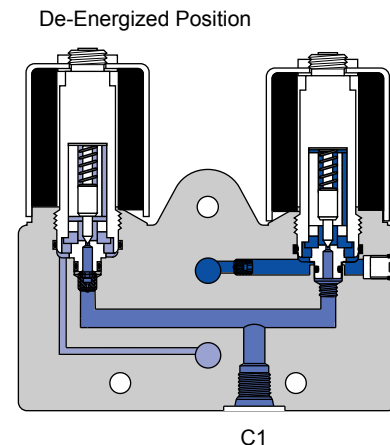

ZMC - LFH Module: High Pressure Low Flow Valve

Description

The LFH module is a three-way, three-position solenoid-operated poppet valve. It is commonly used as directional control for single-acting cylinders with low flow requirements. It has a higher cracking pressure for use with higher pressure flows. This module also contains pressure protection for the work port.

Operation

The direct-acting poppets are spring-biased closed. Energizing the solenoid will open the poppets and allow flow to or from the work port.

Specifications

Weight	3.1 kg	6.9 lb
Ports: Work	#4 SAE 7/16-20	
Response Time (sec)		
Coil Duty:	Intermittent	Continuous
Raise	.15	N/A
Lower	.75	N/A

LFH Cracking Pressure Curve

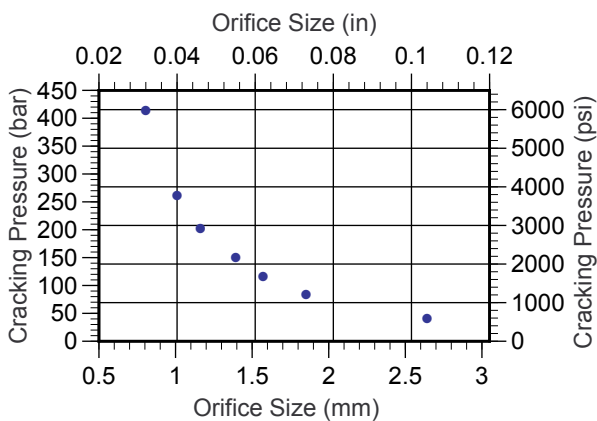

LFH Pressure Drop Curve

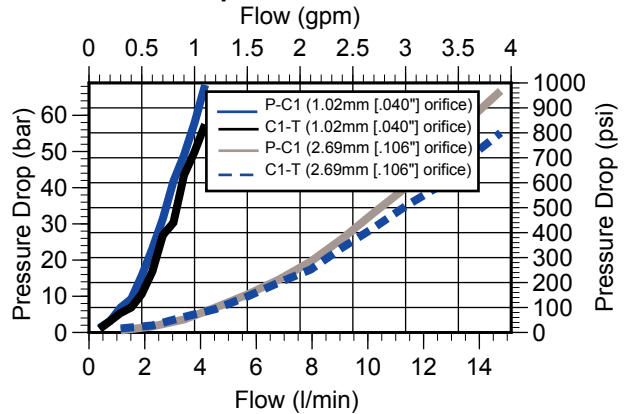

LFH Schematic

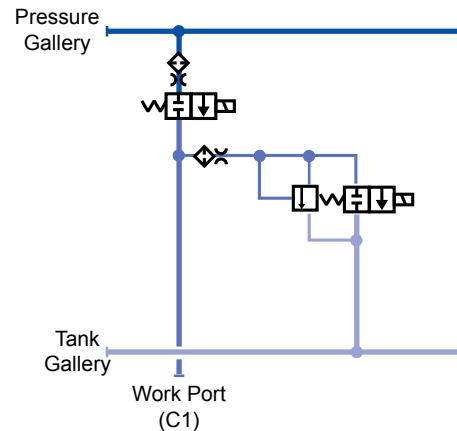

LFH Cut-away

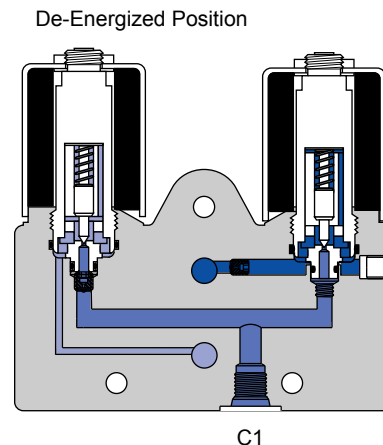

Description

ZMV modules are electronic proportional valve assemblies used to control flow to a motor or other type of actuator. They include pressure compensation to accurately control flow regardless of load pressure. A manually adjustable override is available to bypass the proportional electrical valve. ZMV modules are stand alone units and are not stackable.

ZMV modules are available in open center (21O and 21P) and closed center (21C and 21L) valve configurations. The open center module can include a Power Beyond port to channel excess flow to another function (21P). The closed center module can come with load sensing capability (21L).

Typical applications include variable motor speed circuits on combines, salt spreader applications on trucks, and hydraulic motor conveyers.

Operation

The module's pilot valve is spring-biased normally closed. When a pulse width modulated (PWM) signal of 35 to 100 Hz is applied to the solenoid, the valve will open proportionally to the current. The compensating spool maintains a constant pressure drop across the pilot valve (or manual valve) and therefore pressure compensates the priority flow.

A potentiometer and electronic driver on page 35 or a joystick control on page 36 may be used to supply the valve input signal.

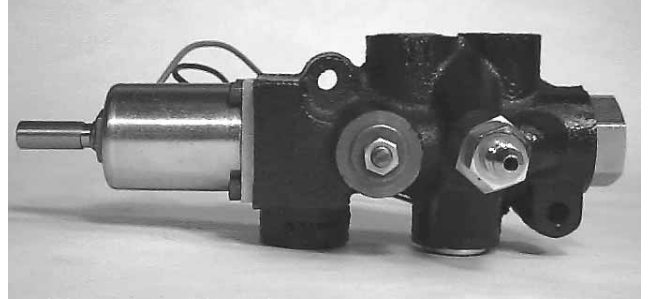



ZMV-210: Open Center Proportional Flow Control Valve

Description

The ZMV 210 valve is designed for open center systems (e.g. fixed displacement pumps). Controlled flow is pressure compensated. Excess flow is always bypassed to tank.

Specifications

Weight		4.2 kg	9.2 lb
Ports:	Pressure	#10 SAE 7/8-14	
	Controlled	#10 SAE 7/8-14	
	Tank	#10 SAE 7/8-14	
PWM Frequency Range		35 - 100 Hz	
PWM Current Range		0 - 1.2 Amps	
Flow:	Pressure	76 l/min	20 gpm
	Controlled	38 l/min	10 gpm

210 Schematic

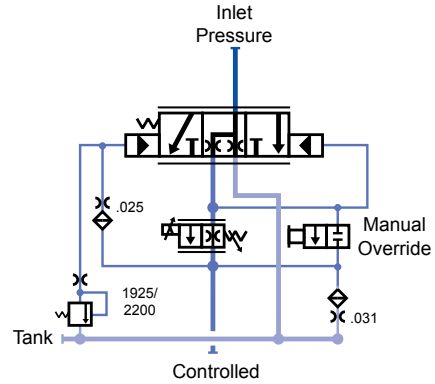

210 Cut-away

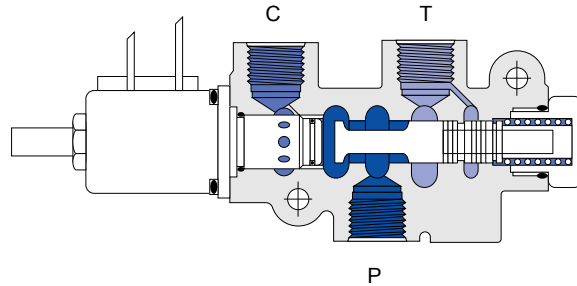

210 Pressure Drop vs Flow Curve

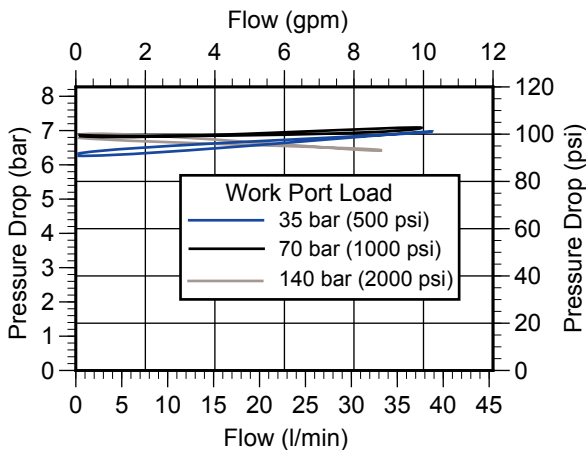

210 Flow vs Current Hysteresis Curve

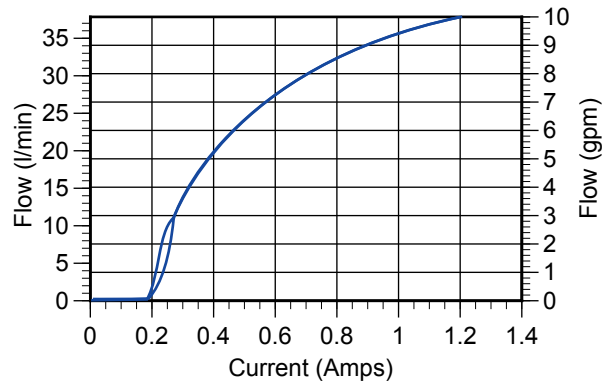

ZMV-21P: Open Center Proportional Flow Control Valve with Power Beyond

Description

The ZMV-21P valve is designed for open center systems (fixed displacement pumps). Controlled flow is pressure compensated. A bypass function unloads excess flow to the Power Beyond port. This flow is not pressure compensated.

Specifications

Weight		4.2 kg	9.2 lb
Ports:	Pressure	#10 SAE 7/8-14	
	Controlled	#10 SAE 7/8-14	
	Power Beyond	#10 SAE 7/8-14	
	Tank	#4 SAE 7/16-20	
PWM Frequency Range		35 - 100 Hz	
PWM Current Range		0 - 1.2 Amps	
Flow:	Pressure	76 l/min	20 gpm
	Controlled	38 l/min	10 gpm

21P Schematic

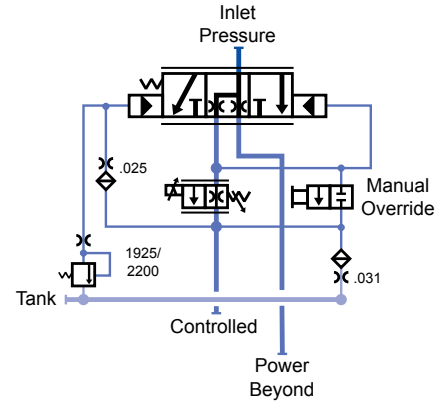

21P Cut-away

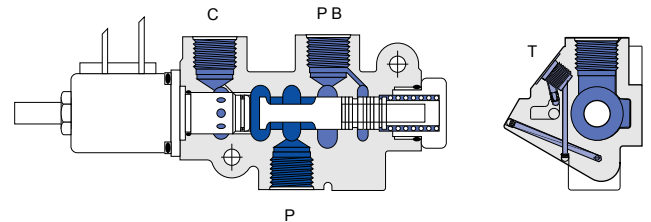

21P Pressure Drop vs Flow Curve

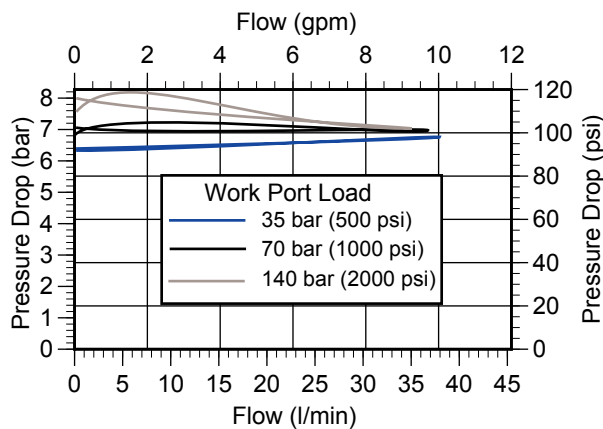

21P Flow vs Current Hysteresis Curve

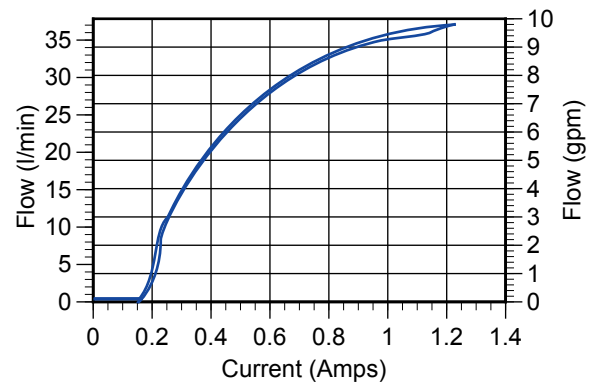



ZMV-21C: Closed Center Proportional Flow Control Valve

Description

The ZMV-21C valve is designed for closed center systems (variable displacement pumps).

Specifications

Weight		4.2 kg	9.2 lb
Ports:	Pressure	#10 SAE 7/8-14	
	Controlled	#10 SAE 7/8-14	
	Tank	#6 SAE 9/16-18	
PWM Frequency Range		35 - 100 Hz	
PWM Current Range		0 - 1.2 Amps	
Flow:	Pressure	76 l/min	20 gpm
	Controlled	38 l/min	10 gpm

21C Schematic

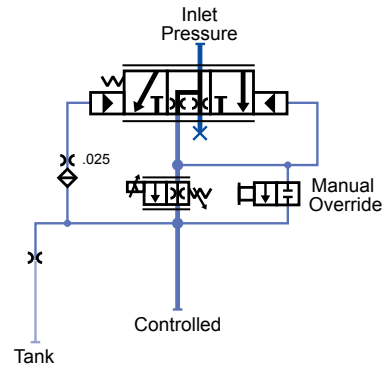

21C Cut-away

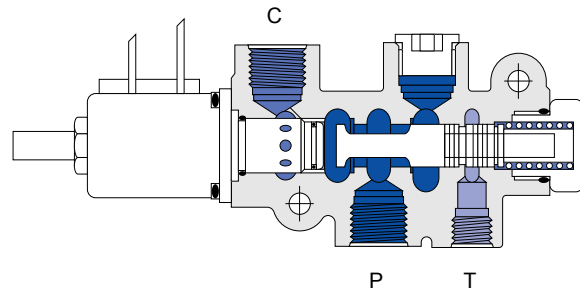

21C Pressure Drop vs Flow Curve

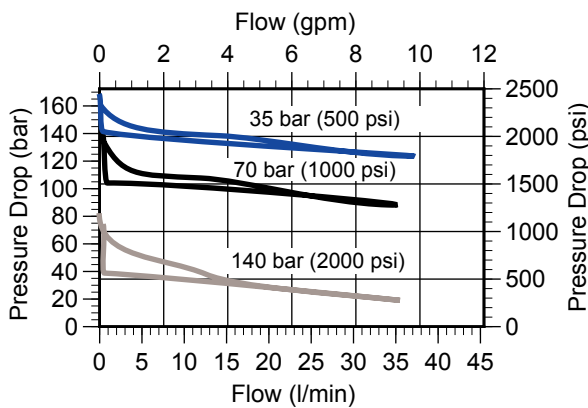

21C Flow vs Current Hysteresis Curve

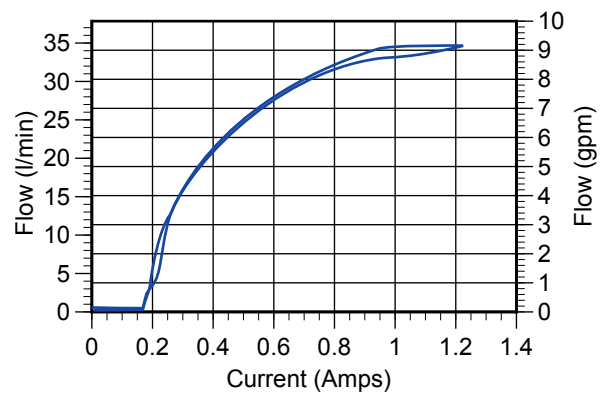

ZMV-21L: Closed Center Load-Sensing Proportional Flow Control Valve

Description

The ZMV-21L valve is designed for closed center load sense systems (variable displacement pumps).

Specifications

Weight		4.2 kg	9.2 lb
Ports:	Pressure	#10 SAE 7/8-14	
	Controlled	#10 SAE 7/8-14	
	Load Sense	#6 SAE 9/16-18	
	Tank	#6 SAE 9/16-18	
PWM Frequency Range		35 - 100 Hz	
PWM Current Range		0 - 1.2 Amps	
Flow:	Pressure	76 l/min	20 gpm
	Controlled	38 l/min	10 gpm

21L Schematic

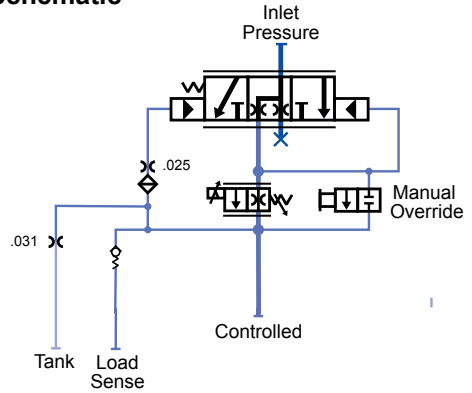

21L Cut-away

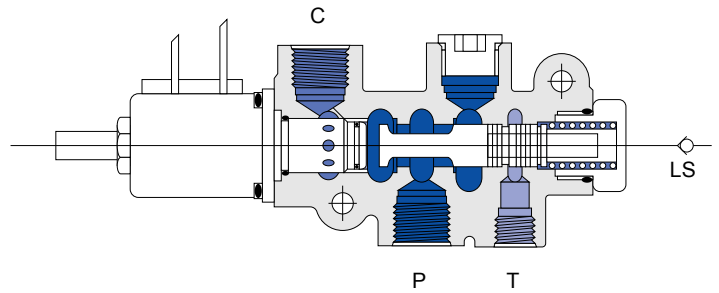

21L Pressure Drop vs Flow Curve

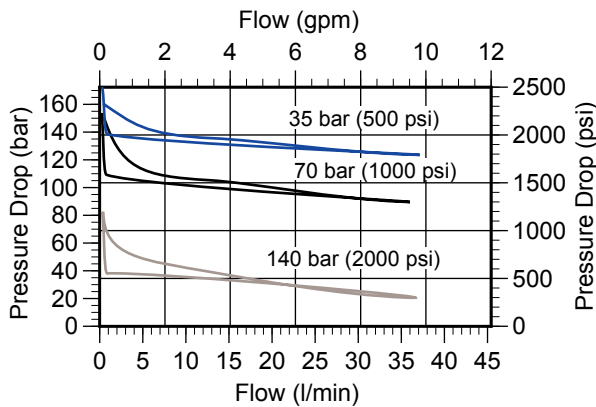

21L Flow vs Current Hysteresis Curve

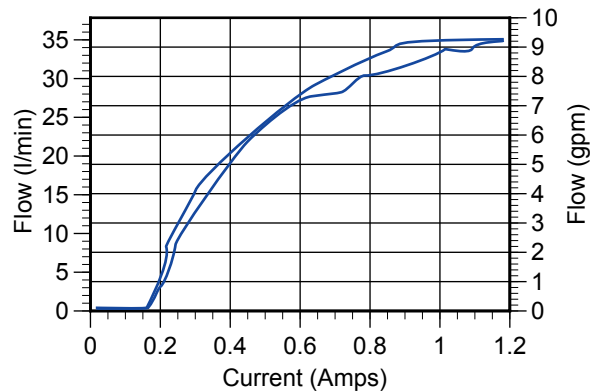

Solenoids

General Description

ZMC and ZMV valves utilize the same solenoid design. This two piece design consists of an encapsulated coil and a metal enclosure.

Several terminations, voltages, and diodes are available. Intermittent solenoids are used to improve response time. Consult duty cycle ratings when using intermittent duty solenoids.

Specifications

Resistance and Wattage:

Continuous duty coil at 20° C (70° F):

Coil Duty:	Continuous		Intermittent	
	Duty Voltage (VDC)	Resistance (Ω)	Power (W)	Resistance (Ω)
6	3.6	10	--	--
12	14.5	10	3.6	40
24	57.2	10	14.5	40

Duty Rating:

Rated voltage at 50° C (120° F):

Continuous Duty	±20%
Intermittent Duty	±20%

Temperature Range:

Class H, -40° C to 82° C (-40° F to 180° F)

Lead Wires:

20 gauge, 18" long

Encapsulating Material:

Cyglass

Arc Suppression Diode (Optional):

IN4004

Coil Nut Torque:

ZMC Valves	7.3 Nm	65 in•lbf
ZMV Valves	2.8 Nm	25 in•lbf

110VAC solenoids are internally rectified. They are rated for reverse voltage spikes of 400 volts maximum.

Standard solenoids are not hermetically sealed. Contact QCC regarding applications requiring waterproof solenoids.

Solenoid Temperature Rise Curve

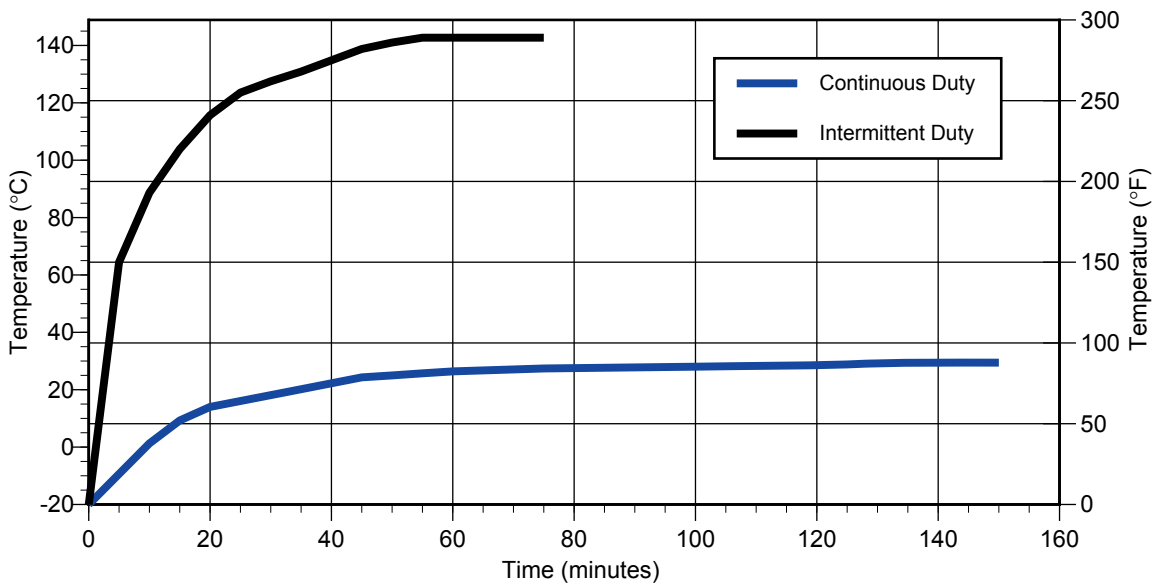

Solenoid Outline Drawings

A variety of solenoids are available to choose from. See the Order Code on page 6 for available voltages. (Mating connectors are not included with solenoid.)

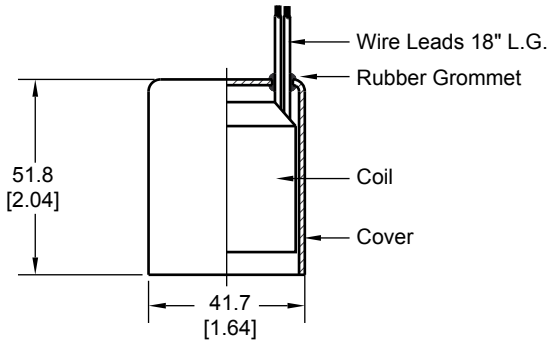

Grommet / Wire Leads

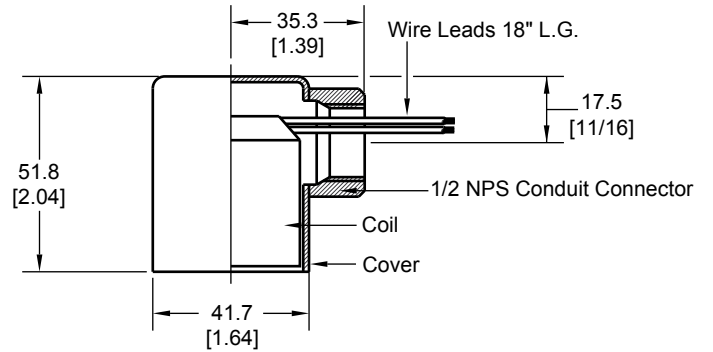

Conduit / Wire Leads

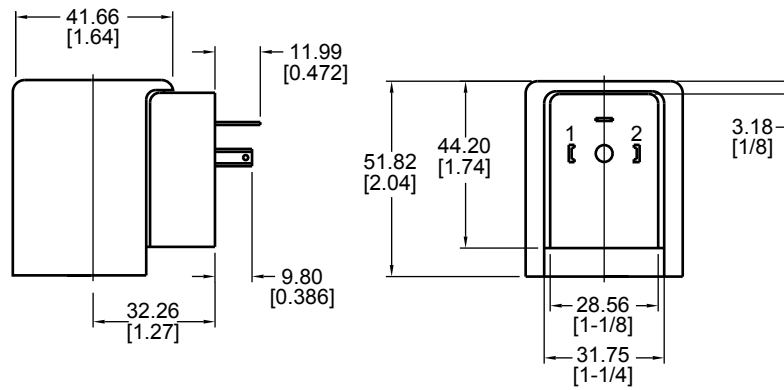

DIN 43650

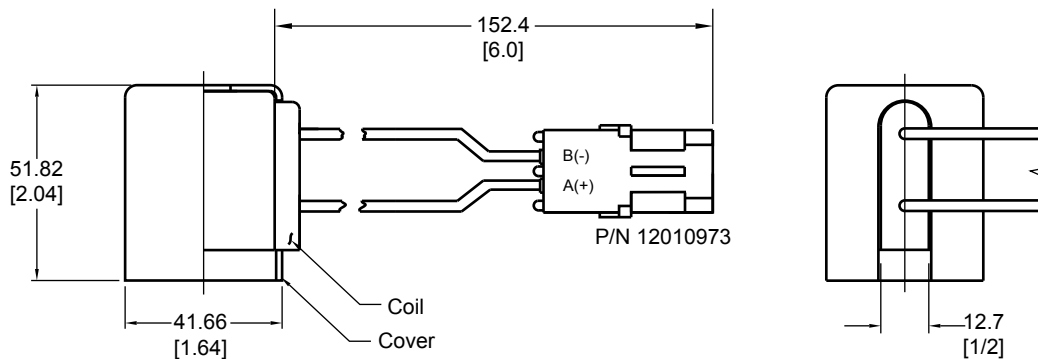

Weather Pack 12010973

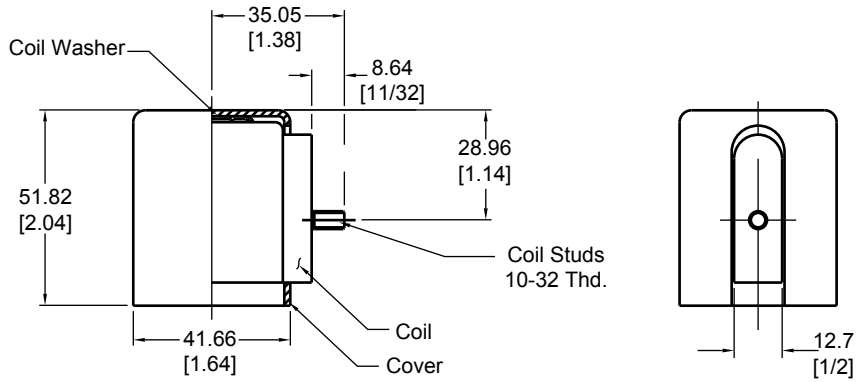

Single Stud

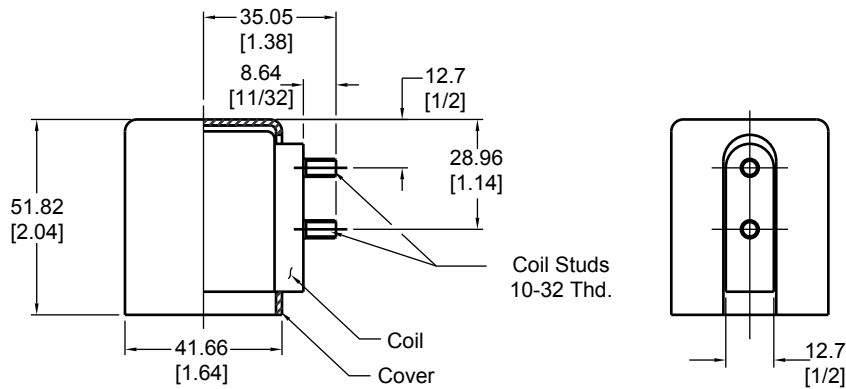

Double Stud

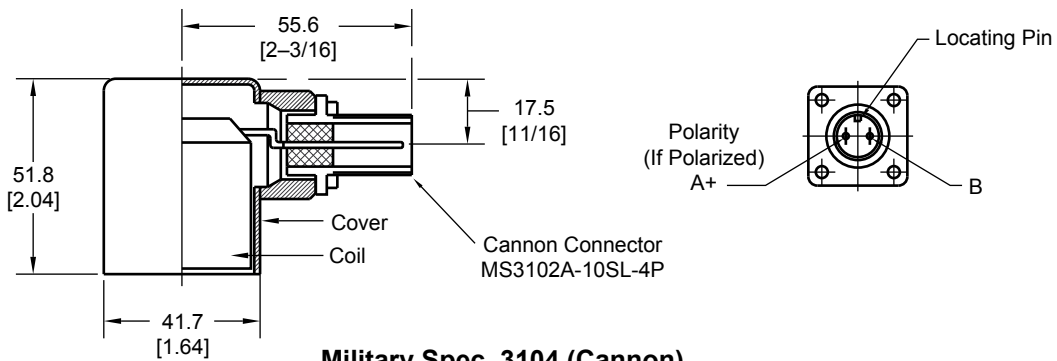

Military Spec. 3104 (Cannon)

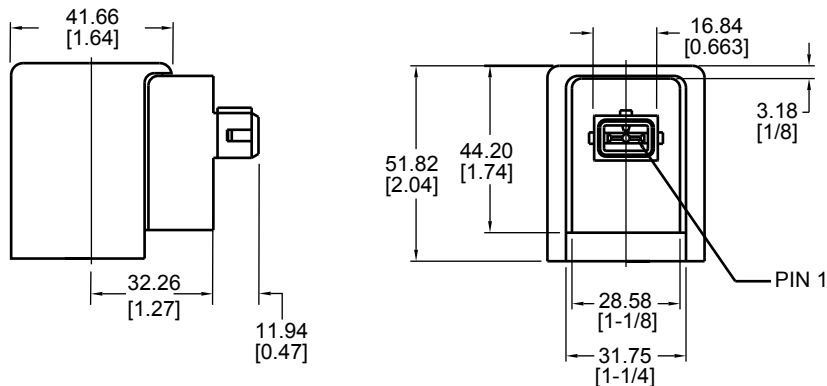

Amp Junior

Control Device Options

SCA-35: Single Channel Amplifier

Description

The SCA-35 single channel amplifier is designed to optimize the performance of ZMV series pressure-compensated flow control valves in handling flows from 4 to 38 l/min (1 to 10 gpm).

The SCA-35's current feedback provides low hysteresis by compensating for fluctuations in input voltage and solenoid resistance. Output overload and arc suppression diode protection is included in the SCA-35. However, arc suppression is also recommended for the valve's coil.

The SCA-35 is fully encapsulated for protection against humidity, vibration, and shock.

Operation

The control signal to the driver is generated by a potentiometer or an analog signal. The amplifier provides no output until the control input is greater than 1% of the internal reference voltage (+5 VDC).

A 2Ω, 2.25 watt resistor with 292of travel is available

from QCC (P/N K10197, Knob P/NK04860).

This system allows the operator to turn off the valve without switching input power. The addition of optional resistors allows the driver to maximize the resolution of the set point potentiometer. These may be fixed resistors or a variable potentiometer.

Specifications

Supply Voltage	9.6 - 16.0 VDC
Operating Frequency	35 Hz
Maximum Continuous Output Current	1.1 Amp
Input signal	>2 kΩ, 0-5 VDC, >1 Amp
Connections <small>(Mating Connectors must be ordered separately.)</small>	Packard Weatherpack 6 pin mating connector (P/N 12015799).
Weight	0.26 kg 0.57 lb
Package Dimensions	99 x 54 x 39 3.9 x 2.1 x 1.5 mm in
Mounting Orientation	any
Temperature Range	-40 to 85°C -40 to 185°F

Output vs. Input

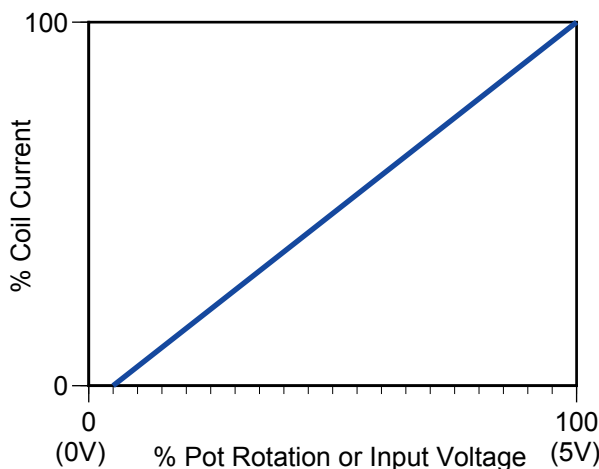

Note: No Output from 0 - .05V

Outline Dimensions

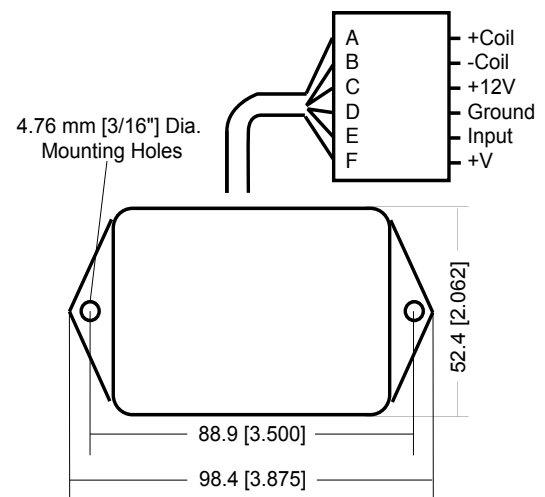



Electronic Control Handle: MCH41CL2287

Description

This panel mount control handle is designed to operate the ZMV series flow control valves. It is enclosed in a plastic case and includes a non-locking knob and friction-held control.

Combined with any ZMV valve, this driver will provide a complete pressure compensated flow control system to handle 4 to 38 l/min (1 to 10 gpm).

The control handle's current feedback provides repeatability by compensating for fluctuations in input voltage and solenoid resistance. Output overload and arc suppression protection is included in the control handle. However, arc suppression is also recommended for the coil.

Operation

The control signal to the driver is generated by a potentiometer located in the control handle. The amplifier provides no output until the control input is greater than 1% of the internal reference voltage (+5 VDC). This allows the operator to turn off the valve without switching input power.

Specifications

Supply Voltage	9.6 - 16.0 VDC
Operating Frequency	100 Hz
Maximum Output Current	1.1 Amp
Input signal	> 2 kΩ, 0-5 VDC, > 1 Amp
Connections	Packard Weatherpack 6 pin mating connector (P/N 12015799) Mating connectors are not included.
Weight	0.26 kg 0.57 lb
Temperature Range	-40 - 85°C -40 - 185°F

Outline Drawings

For other control handle options consult SAS BLN 95-9049

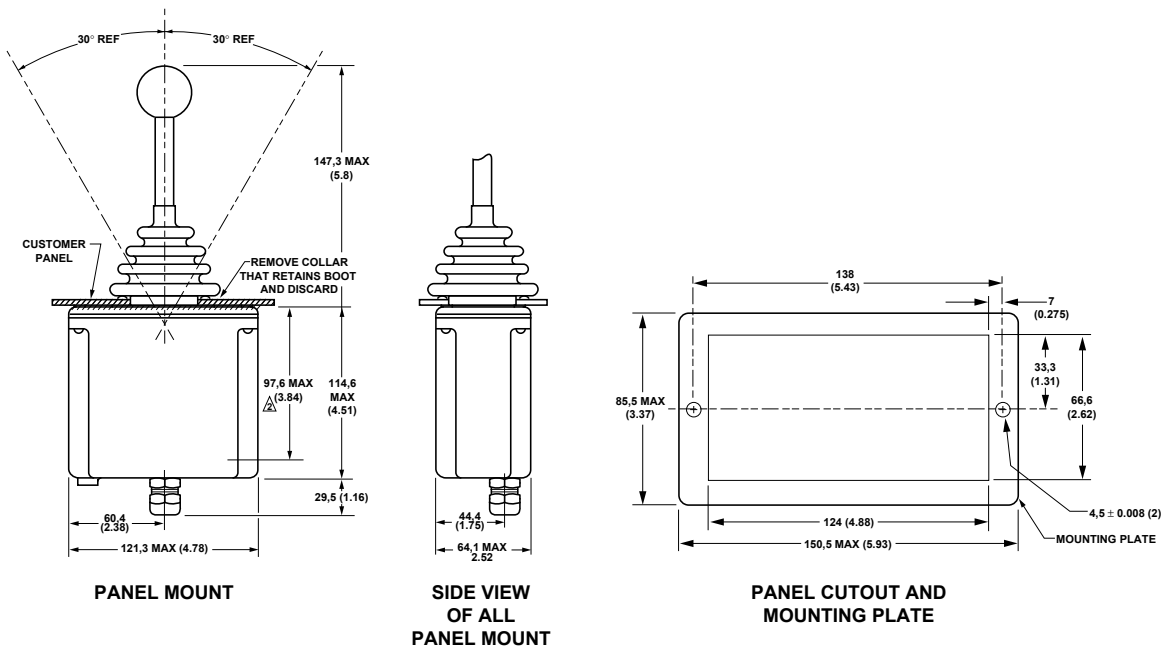



Orifice Plugs / Plates

Standard threaded orifice plugs are available to mount in the ZMC-240, 24C, 340, 34C, 34X, and 34Y modules. Orifice plates are also available to place in

the work ports of the above modules. Below are graphs showing the orifice size required based on the flow and pressure drop desired.

Orifice Size for Specific Flow and Pressure Drop

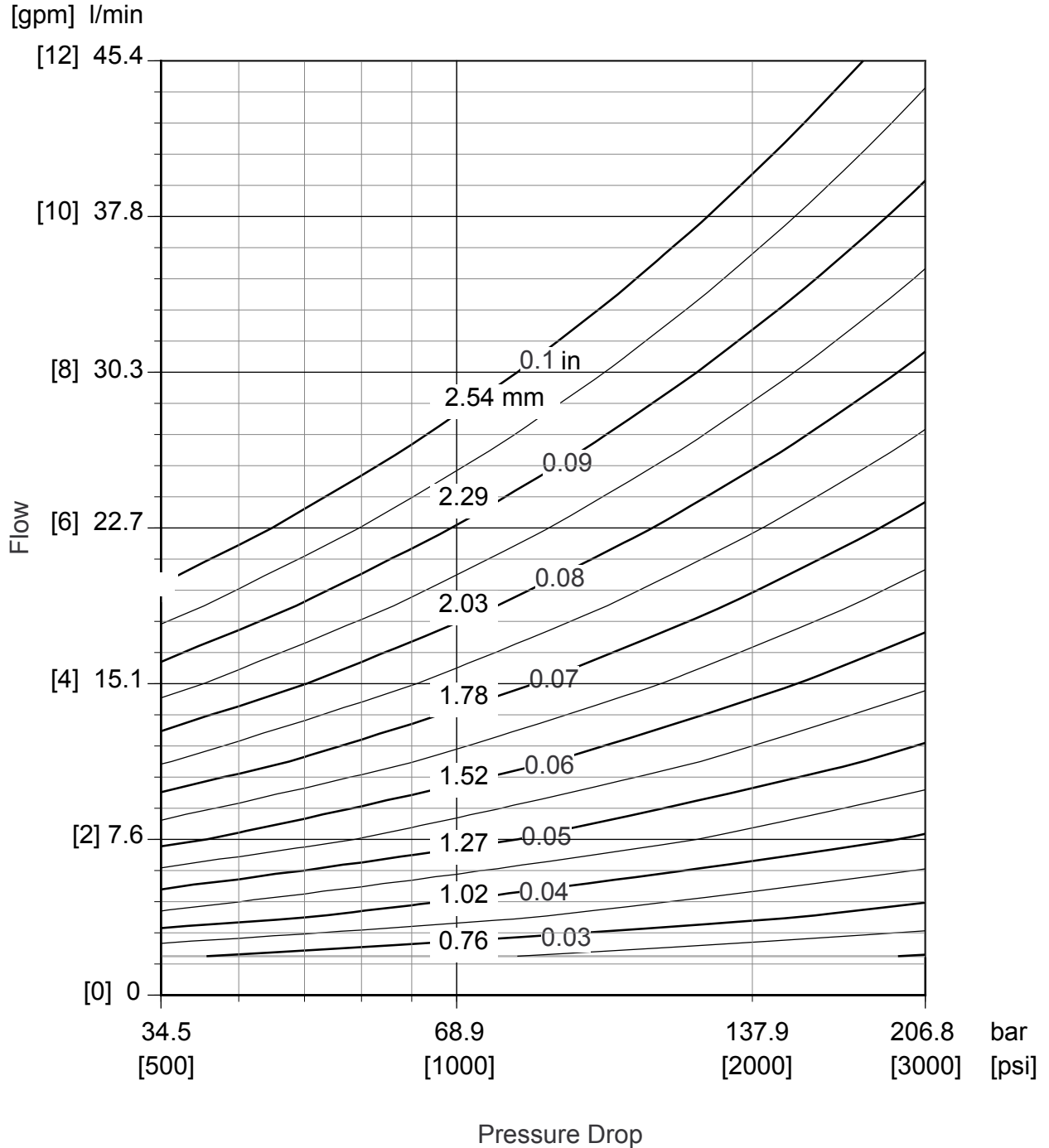

Required Assembly Hardware

Through Tubes / Plug Tubes

All ZMC modules utilize common pressure and tank galleries running through the length of the valve stack. Each through tube includes two sets of O-rings and back up rings for elimination of leakage between the modules.

Three tie bolts are used in each ZMC valve stack to join the modules together. The through tubes assist in aligning the modules into the stack. This eliminates the spool binding that occurs due to over torquing the tie bolts or mounting to uneven surfaces.

Plug tubes are used to seal the pressure and tank galleries at the end of the valve stack. To add modules to an assembled valve stack the plug tubes can be removed and replaced by a through tube to accommodate additional modules.

Plug tubes can also be used to isolate a particular module's pressure and/or tank gallery from the rest of the stack.

Tube Part Numbers

Plug Tube	Z2819006
Standard Through Tube	Z2812011
Long Through Tube	Z2812012

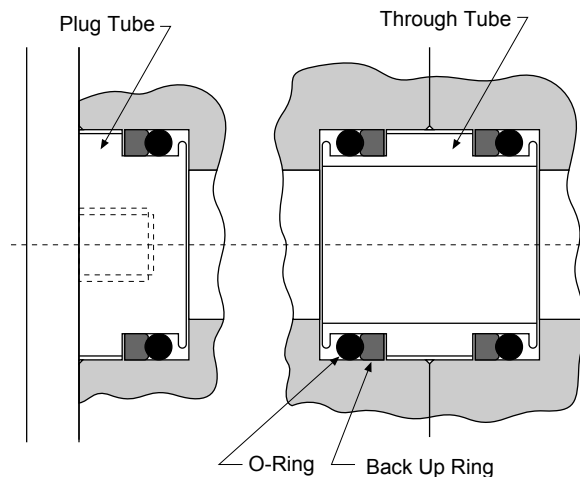
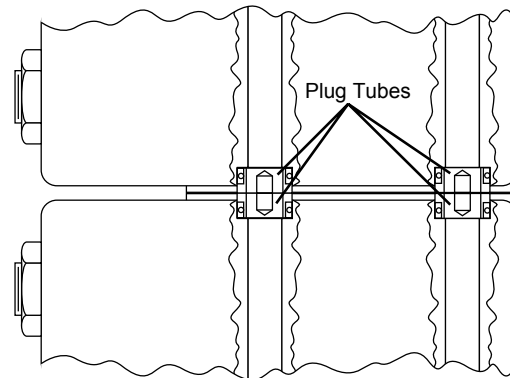
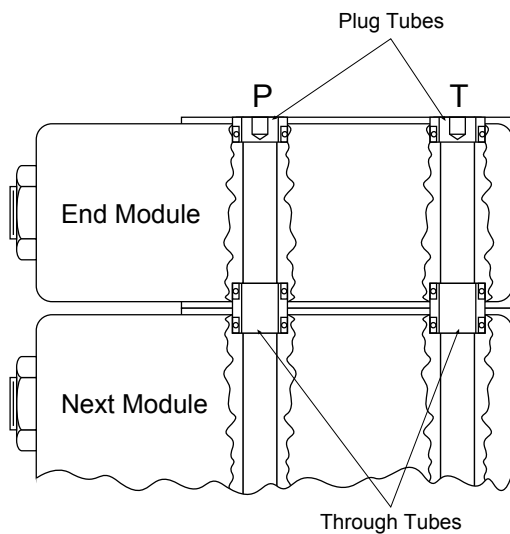

Stacking Configurations

Valve assemblies can be mounted in any direction, but for clarity a valve stack with "L" brackets is referred to as "**Horizontal**" and a stack without "L" brackets as "**Vertical**" (see figures).

"L" feet mounting brackets and end plates are provided to support the complete stack. The brackets are stamped from steel and zinc plated. Tie bolts are used to fasten the stack together. Pressure and tank connections are made either through the appropriate

end caps or through the Unload modules (UVx, URx). Plug tubes are inserted in the end modules to seal the pressure and tank galleries.

An alternative mounting style is to use the tie bolts to fasten the valve stack to a customer-supplied metal plate.

All ZMC modules can also be utilized as stand alone line mount valves.

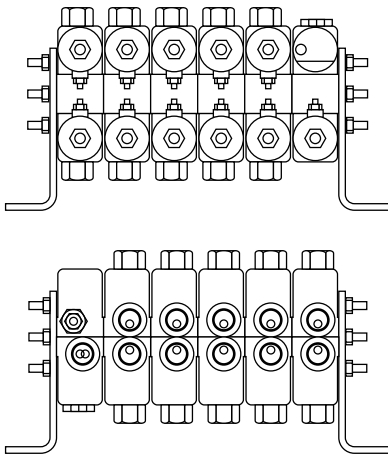

"Horizontal" Stack Assembly

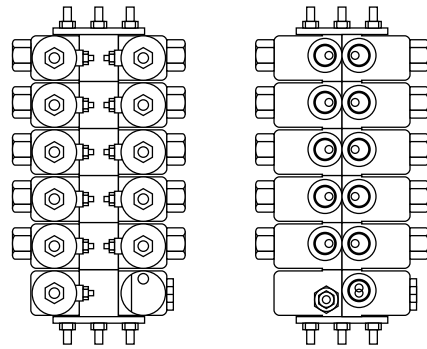

"Vertical" Stack Assembly

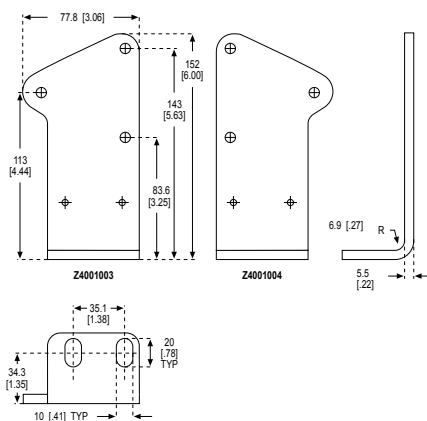

"L" Mounting Bracket

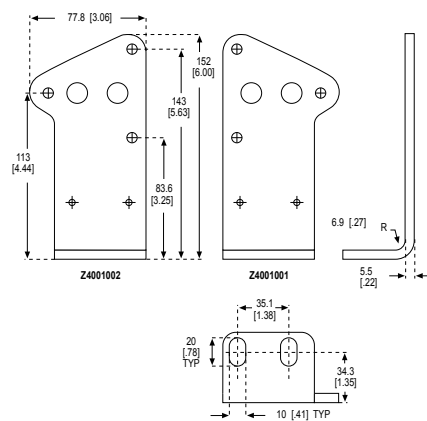

"L" Mounting Bracket with Port Access



Stacking Kits

Currently six stacking kit configurations are offered. These are listed in tables on the following pages.

Stack Type	Hardware	Table
Horizontal	Two Mounting Brackets, No End Caps	A
Horizontal	Two Mounting Brackets, One End Cap with Ports Right	B
Horizontal	Two Mounting Brackets, One End Cap with Ports Left	C
Horizontal	Two Mounting Brackets, Two End Caps with Ports	D
Vertical	Two End Plates, One Tapped	E
Vertical	One Tapped End Plate, One End Cap with Ports	F

These stacking kits include all the hardware to assemble up to eight individual valve modules into a single valve stack. "End caps *with ports*" must be ordered separately due to individual port requirements. The standard end cap is P/N Z4001010, this has two SAE-8 ports (see page 45 for others).

For vertical stacks, tapped end plates eliminate the need for nuts and washers at the end of the stack.

The tapped end plates are attached to the stack via the through-bolt.

A stacking kit part number is determined as follows:

1. Decide if a **Horizontal** or **Vertical** configuration (described above) is required.
2. Determine if an end cap *with ports* is required. If no unload module (UVx, URx) is used, an end cap *with ports* must be used. This allows the pressure and tank lines to be connected to the valve stack.
3. Go to the table that corresponds to the configuration required. Under the column indicating the correct number of modules choose the corresponding part number for either a factory-assembled stack or an unassembled stack kit.

Factory assembled stacks will be completely assembled and pressure-tested as a stack. A single "stack" part number will be generated for reordering.

When ordering please supply either the stack part number or all module order codes (page 6) and corresponding stacking kit part numbers.

Table A: Horizontal Configuration, Two Mounting Brackets, No End Caps

Number of Modules in Stack		1	2	3	4	5	6	7	8	N U M B E R O F P I E C E S P E R K I T
Factory Assembled Stacking Kit P/N		Z6917001	Z6917002	Z6917003	Z6917004	Z6917005	Z6917006	Z6917007	Z6917008	
Unassembled Stacking Kit P/N		Z6911001	Z6911002	Z6911003	Z6911004	Z6911005	Z6911006	Z6911007	Z6911008	
PART NUMBER	DESCRIPTION									
Z2812011	THRU-TUBE	-	2	4	6	8	10	12	14	
Z2812012	LONG THRU-TUBE	-	-	-	-	-	-	-	-	
Z2819006	PLUG TUBE	4	4	4	4	4	4	4	4	
Z8229001	HEX NUT	3	3	6	6	6	6	6	6	
Z8230001	LOCKWASHER	6	6	6	6	6	6	6	6	
Z4001004	RIGHT BRACKET	1	1	1	1	1	1	1	1	
Z4001003	LEFT BRACKET	1	1	1	1	1	1	1	1	
TIE-RODS		(in) LENGTH (mm)								
Z8240009	3	76.2	3	-	-	-	-	-	-	
Z8240016	4-3/4	120.6	-	3	-	-	-	-	-	
Z8208001	7-1/4	184.2	-	-	3	-	-	-	-	
Z8208008	9	228.6	-	-	-	3	-	-	-	
Z8208015	10-3/4	273.0	-	-	-	-	3	-	-	
Z8208022	12-1/2	317.5	-	-	-	-	-	3	-	
Z8208029	14-1/4	361.9	-	-	-	-	-	-	3	
Z8208036	16	406.4	-	-	-	-	-	-	-	3



Table B: Two Mounting Brackets, One End Cap with Ports Right, Horizontal Configuration

Number of Modules in Stack			1	2	3	4	5	6	7	8	N U M B E R O F P I E C E S P E R K I T
Factory Assembled Stacking Kit P/N			Z69180001	Z69180002	Z69180003	Z69180004	Z69180005	Z69180006	Z69180007	Z69180008	
			Z69120001	Z69120002	Z69120003	Z69120004	Z69120005	Z69120006	Z69120007	Z69120008	
PART NUMBER	DESCRIPTION										
Z2812011	THRU-TUBE		-	2	4	6	8	10	12	14	
Z2812012	LONG THRU-TUBE		2	2	2	2	2	2	2	2	
Z2819006	PLUG TUBE		2	2	2	2	2	2	2	2	
Z8229001	HEX NUT		3	3	6	6	6	6	6	6	
Z8230001	LOCKWASHER		6	6	6	6	6	6	6	6	
Z4001003	LEFT BRACKET		1	1	1	1	1	1	1	1	
Z4001001	PORTED RIGHT BRACKET		1	1	1	1	1	1	1	1	
TIE-RODS (in) LENGTH (mm)											
Z8240016	4-3/4	120.6	3	-	-	-	-	-	-	-	
Z8240022	6-5/16	160.3	-	3	-	-	-	-	-	-	
Z8208001	7-1/4	184.2	-	-	3	-	-	-	-	-	
Z8208008	9	228.6	-	-	-	3	-	-	-	-	
Z8208018	11-1/2	292.1	-	-	-	-	3	-	-	-	
Z8208025	13-1/4	336.5	-	-	-	-	-	3	-	-	
Z8208032	15	381.0	-	-	-	-	-	-	3	-	
Z8208039	16-3/4	425.4	-	-	-	-	-	-	-	3	

Table C: Two Mounting Brackets, One End Cap with Ports Left, Horizontal Configuration

Number of Modules in Stack			1	2	3	4	5	6	7	8	N U M B E R O F P I E C E S P E R K I T
Factory Assembled Stacking Kit P/N			Z69220001	Z69220002	Z69220003	Z69220004	Z69220005	Z69220006	Z69220007	Z69220008	
			Z69160001	Z69160002	Z69160003	Z69160004	Z69160005	Z69160006	Z69160007	Z69160008	
PART NUMBER	DESCRIPTION										
Z2812011	THRU-TUBE		-	2	4	6	8	10	12	14	
Z2812012	LONG THRU-TUBE		2	2	2	2	2	2	2	2	
Z2819006	PLUG TUBE		2	2	2	2	2	2	2	2	
Z8229001	HEX NUT		3	3	6	6	6	6	6	6	
Z8230001	LOCKWASHER		6	6	6	6	6	6	6	6	
Z4001004	RIGHT BRACKET		1	1	1	1	1	1	1	1	
Z4001002	PORTED LEFT BRACKET		1	1	1	1	1	1	1	1	
TIE-RODS (in) LENGTH (mm)											
Z8240016	4-3/4	120.6	3	-	-	-	-	-	-	-	
Z8240022	6-5/16	160.3	-	3	-	-	-	-	-	-	
Z8208001	7-1/4	184.2	-	-	3	-	-	-	-	-	
Z8208008	9	228.6	-	-	-	3	-	-	-	-	
Z8208018	11-1/2	292.1	-	-	-	-	3	-	-	-	
Z8208025	13-1/4	336.5	-	-	-	-	-	3	-	-	
Z8208032	15	381.0	-	-	-	-	-	-	3	-	
Z8208039	16-3/4	425.4	-	-	-	-	-	-	-	3	



Table D: Two Mounting Brackets, Two End Caps with Ports, Horizontal Configuration

Number of Modules in Stack			1	2	3	4	5	6	7	8	N U M B E R O F P I E C E S P E R K I T
Factory Assembled Stacking Kit P/N			Z69190001	Z69190002	Z69190003	Z69190004	Z69190005	Z69190006	Z69190007	Z69190008	
			Z69130001	Z69130002	Z69130003	Z69130004	Z69130005	Z69130006	Z69130007	Z69130008	
PART NUMBER	DESCRIPTION										
Z2812011	THRU-TUBE		-	2	4	6	8	10	12	14	
Z2812012	LONG THRU-TUBE		4	4	4	4	4	4	4	4	
Z2819006	PLUG TUBE		-	-	-	-	-	-	-	-	
Z8229001	HEX NUT		3	3	6	6	6	6	6	6	
Z8230001	LOCKWASHER		6	6	6	6	6	6	6	6	
Z4001001	PORTED RIGHT BRACKET		1	1	1	1	1	1	1	1	
Z4001002	PORTED LEFT BRACKET		1	1	1	1	1	1	1	1	
TIE-RODS (in) LENGTH (mm)											
Z8240016	4-3/4	120.6	3	-	-	-	-	-	-	-	
Z8240022	6-5/16	160.3	-	3	-	-	-	-	-	-	
Z8208004	8	203.2	-	-	3	-	-	-	-	-	
Z8208015	10-3/4	273.0	-	-	-	3	-	-	-	-	
Z8208022	12-1/2	317.5	-	-	-	-	3	-	-	-	
Z8208029	14-1/4	361.9	-	-	-	-	-	3	-	-	
Z8208036	16	406.4	-	-	-	-	-	-	3	-	
Z8208043	17-3/4	450.8	-	-	-	-	-	-	-	3	

Table E: Two End Plates, One Tapped, Vertical Configuration

Number of Modules in Stack			1	2	3	4	5	6	7	8	N U M B E R O F P I E C E S P E R K I T
Factory Assembled Stacking Kit P/N			Z69200001	Z69200002	Z69200003	Z69200004	Z69200005	Z69200006	Z69200007	Z69200008	
			Z69140001	Z69140002	Z69140003	Z69140004	Z69140005	Z69140006	Z69140007	Z69140008	
PART NUMBER	DESCRIPTION										
Z2812011	THRU-TUBE		-	2	4	6	8	10	12	14	
Z2812012	LONG THRU-TUBE		-	-	-	-	-	-	-	-	
Z2819006	PLUG TUBE		4	4	4	4	4	4	4	4	
Z8229001	HEX NUT		-	-	3	3	3	3	3	3	
Z8230001	LOCKWASHER		3	3	3	3	3	3	3	3	
Z4001007	END PLATE		1	1	1	1	1	1	1	1	
Z4001006	TAPPED END PLATE		1	1	1	1	1	1	1	1	
TIE-RODS (in) LENGTH (mm)											
Z8240009	3	76.2	3	-	-	-	-	-	-	-	
Z8240016	4-3/4	120.6	-	3	-	-	-	-	-	-	
Z8208001	7-1/4	184.2	-	-	3	-	-	-	-	-	
Z8208008	9	228.6	-	-	-	3	-	-	-	-	
Z8208015	10-3/4	273.0	-	-	-	-	3	-	-	-	
Z8208022	12-1/2	317.5	-	-	-	-	-	3	-	-	
Z8208029	14-1/4	361.9	-	-	-	-	-	-	3	-	
Z8208036	16	406.4	-	-	-	-	-	-	-	3	

Table F: One Tapped End Plate, One End Cap with Ports, Vertical Configuration

Number of Modules in Stack			1	2	3	4	5	6	7	8
Factory Assembled Stacking Kit P/N			Z6921001	Z6921002	Z6921003	Z6921004	Z6921005	Z6921006	Z6921007	Z6921008
			Z6915001	Z6915002	Z6915003	Z6915004	Z6915005	Z6915006	Z6915007	Z6915008
PART NUMBER	DESCRIPTION									
Z2812011	THRU-TUBE		2	4	6	8	10	12	14	16
Z2812012	LONG THRU-TUBE		-	-	-	-	-	-	-	-
Z2819006	PLUG TUBE		2	2	2	2	2	2	2	2
Z8229001	HEX NUT		-	-	3	3	3	3	3	3
Z8230001	LOCKWASHER		3	3	3	3	3	3	3	3
Z4001007	END PLATE		-	-	-	-	-	-	-	-
Z4001006	TAPPED END PLATE		1	1	1	1	1	1	1	1
TIE-RODS			(in) LENGTH (mm)							
Z8240015	4-1/2	114.3	3	-	-	-	-	-	-	-
Z8240022	6-5/16	160.3	-	3	-	-	-	-	-	-
Z8208004	8	203.2	-	-	3	-	-	-	-	-
Z8208011	9-3/4	247.6	-	-	-	3	-	-	-	-
Z8208018	11-1/2	292.1	-	-	-	-	3	-	-	-
Z8208025	13-1/4	336.5	-	-	-	-	-	3	-	-
Z8208032	15	381.0	-	-	-	-	-	-	3	-
Z8208039	16-3/4	425.4	-	-	-	-	-	-	-	3

NUMBER OF PIECES PER KIT

Module Identification

Each valve module includes a nameplate affixed to the housing. This information includes:

Model Number: This defines the specific unit.

Serial Number: This is used to identify the manufacturing location, build date, and the sequence in the build.





ZMC and ZMV Electrohydraulic Valves
 Technical Information
 Outline Drawings

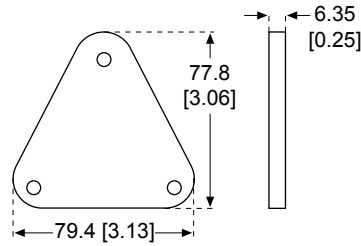

Z4001007—Thru Holes
 Z4001006—1/4-20 Tapped Holes

END PLATES

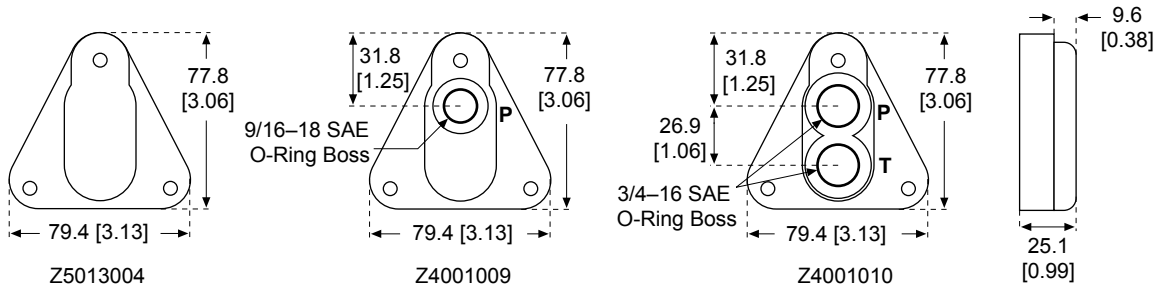

END CAPS

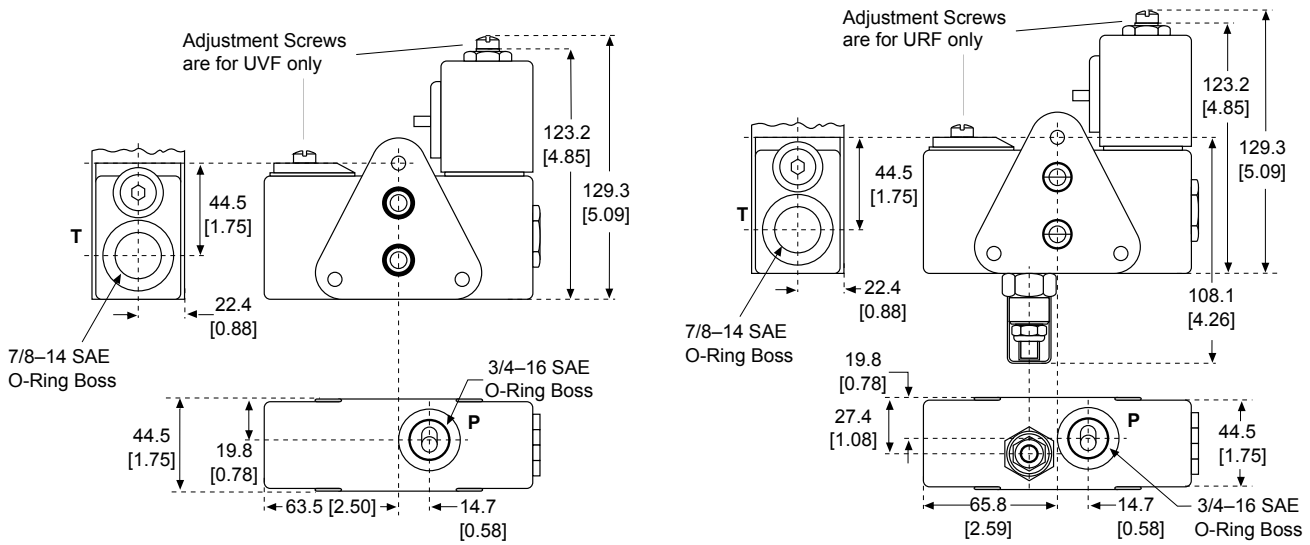

ZMC-UVO, ZMC-UVC, ZMC-UVF

ZMC-URO, ZMC-URF

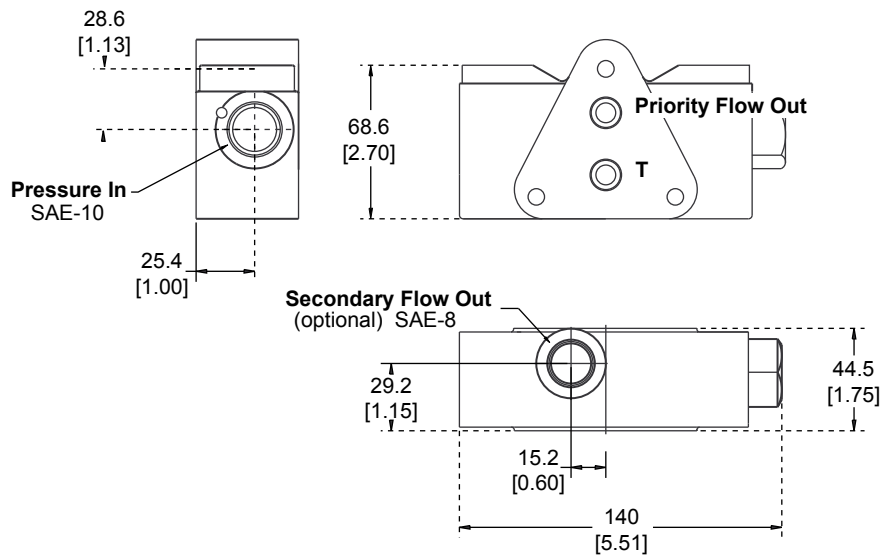

ZMC-PFD

Adjustable Relief

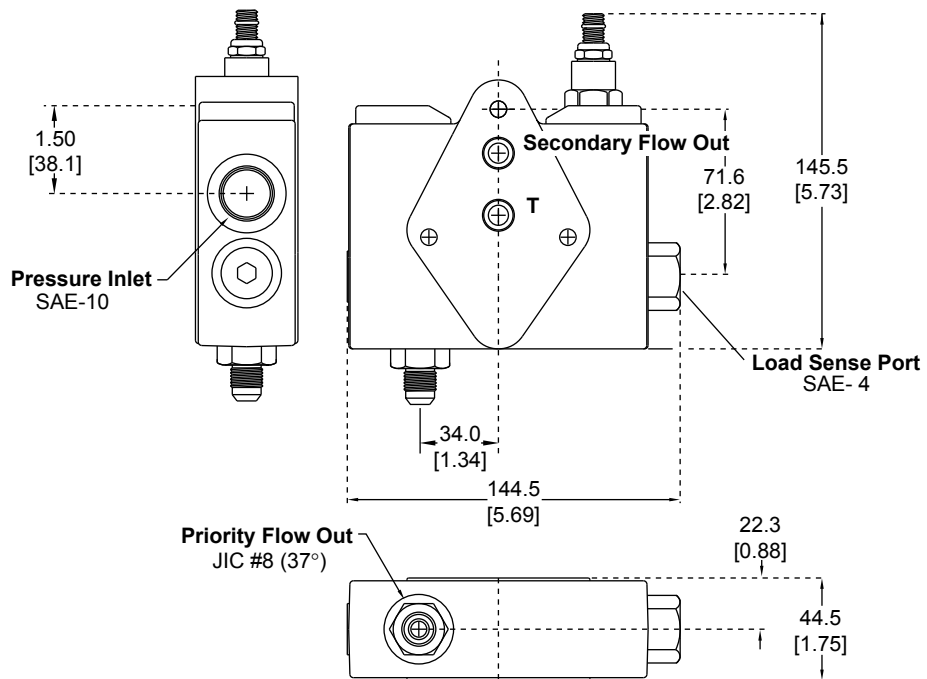

ZMC-DPV

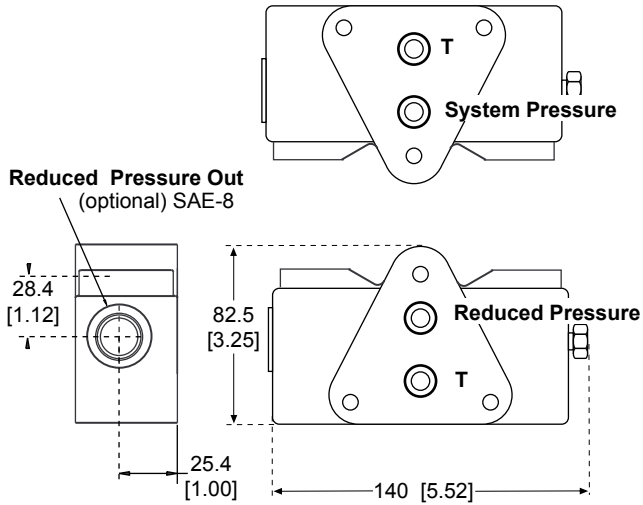

ZMC-PRV

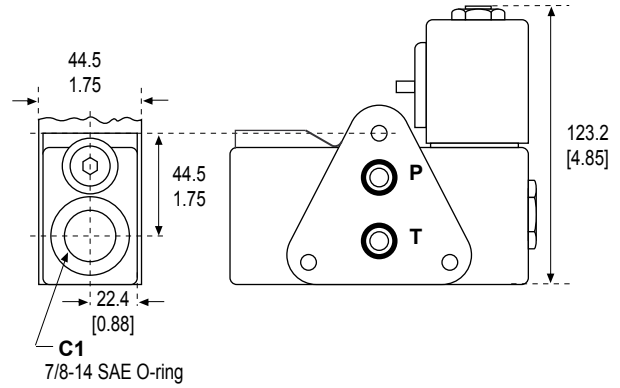

ZMC-SOV

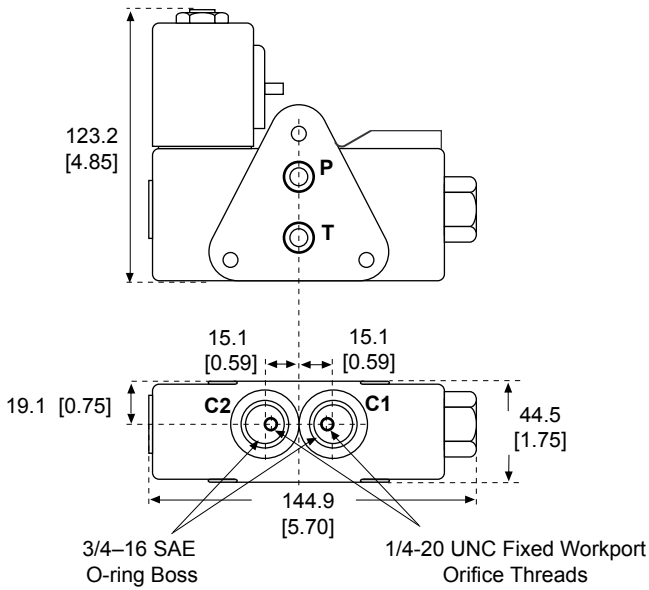

ZMC-240

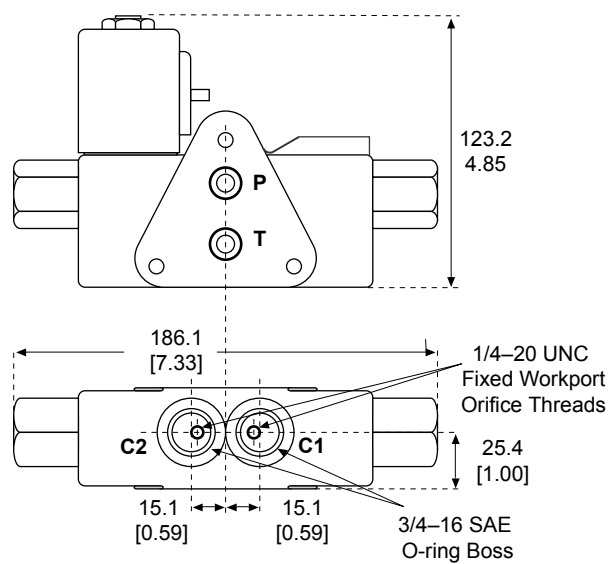

ZMC-24C

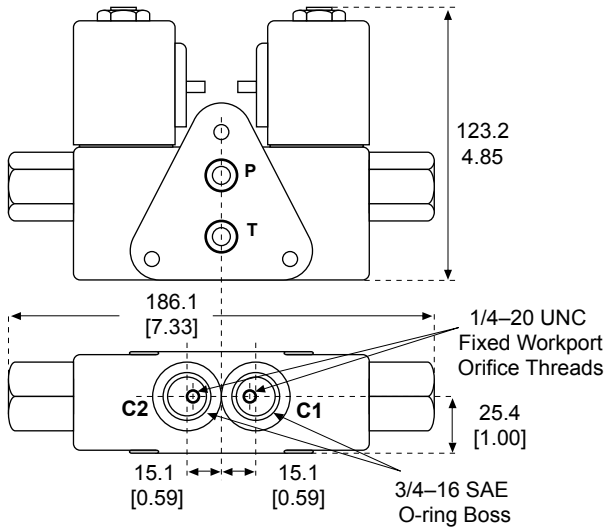

ZMC-340, ZMC-34C

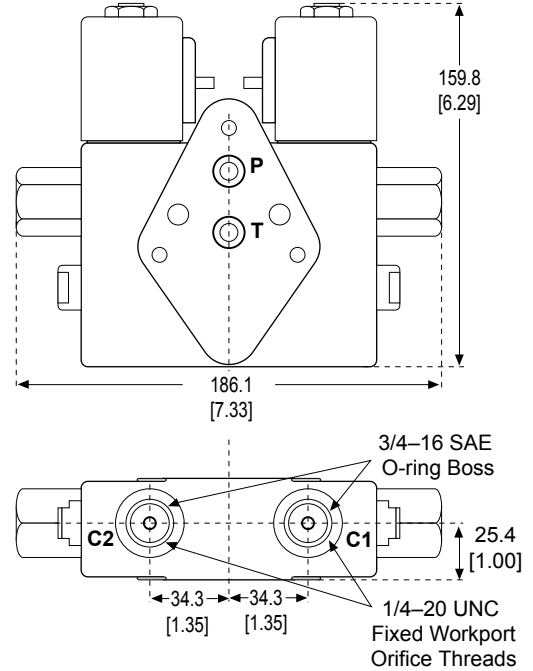

ZMC-34X, ZMC-34Y

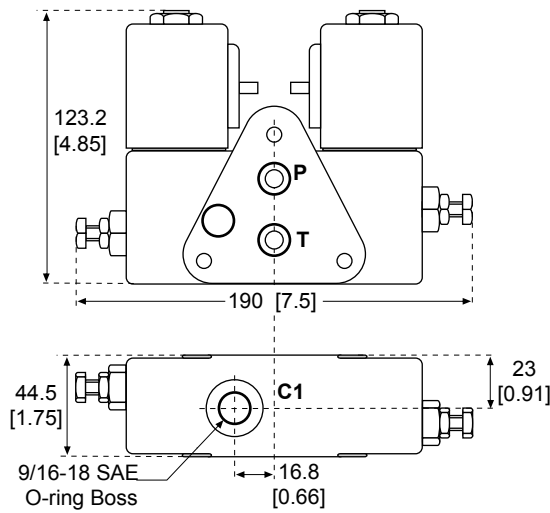

ZMC-PPV

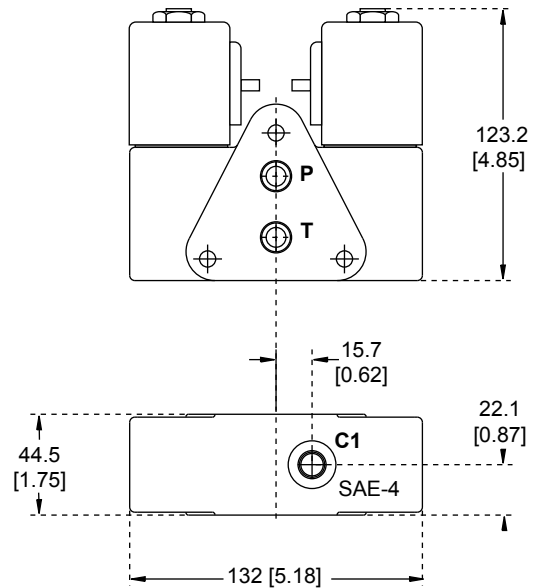

ZMC-LFS, ZMC-LFH



7315 West Wilson Avenue
Chicago, IL 60656
708-867-5400
www.websterproducts.com